

**FiveFish**

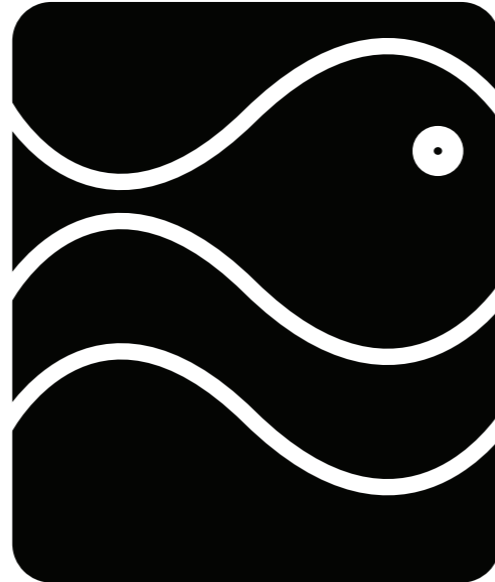

**Studios**

**SK-1DI Mic Preamp + DI Kit  
Assembly Guide**



Assembly Guide Revision 1.4 - 20170214

No part of this document may be reproduced, either mechanically or electronically, posted online on the Internet, in whole or in part, without the expressed, written permission of FiveFish Audio. This document is solely provided to the kit builder of the SC-1KDI Mic Preamp.

Copyright © 2017 FiveFish Audio  
fivefishaudio.com

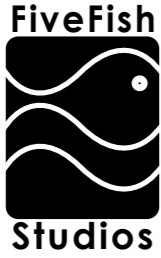

## FiveFish Audio

[www.fivefishaudio.com](http://www.fivefishaudio.com)

Dear Customer,

Thank you for purchasing our SK-1DI Mic Preamp + DI Kit.

Great care has been taken to make this assembly guide complete and as accurate as possible. Our goal is to make your assembly work easy and trouble-free, and deliver to you a working, reliable, and high-performance mic preamplifier.

This assembly guide is a work in progress and we're continually working to improve it. As always, we welcome the input of the DIY community if you have any comments, suggestions, or additional information that you think will be helpful for inclusion in this assembly guide.

If you have any questions that are not covered by this assembly guide, please feel free to contact us at [www.fivefishaudio.com](http://www.fivefishaudio.com), or via our facebook page.

Sincerely,

FiveFish Team

# SAFETY CONSIDERATIONS

## GENERAL

This assembly guide must be reviewed for familiarization with safety markings and instructions before assembly of the Electronic Load kit.

## BEFORE APPLYING POWER

Verify that all components and parts are inserted in the right location and correct orientation. Visually inspect that there are no cold solder joints, or short-circuits. See Step 5 below.

### WARNING

The WARNING sign denotes a hazard. Pay attention to the procedure, instructions, or the like, which if not correctly performed could result in damage to your equipment, electronic component or personal injury.

### WARNING

*Any interruption or disconnection, or lack of connection of the protective earth terminal/safety ground may cause a potential electric shock hazard that could result in personal injury. (Grounding one conductor of a two conductor outlet is not sufficient protection).*

*This mic preamp module is designed to be plug-in into an API 500 series rack or compatible unit. DC Power is supplied by the 500 series rack to this module.*

*It is strongly suggested that you use a lab power supply the **first-time** you power your mic preamp project. If you made any mistake during assembly of this kit (for example: components inserted in wrong location, wrong orientation, short-circuit in your soldering job, etc.) you will not be subjecting the built-in power supply of your rack to the problem, and avoid damaging your power supply.*

*If you don't have a lab power supply and instead will be using your rack to power directly this project the first time, I recommend using an extender card with built-in fuses to protect your rack power supply from accidental shorts or over-current. (The in-line fuses will blow if there is overcurrent or short-circuit condition, thus protecting the rack power supply).*

# GENERAL INFORMATION

## 1. DESCRIPTION

The SK-1DI Kit is a high-performance, low-noise Mic Preamp and Direct Inject (DI) combo unit for use with API 500 Series lunchboxes or racks.

The SK-1DI design utilizes the high-performance THAT preamplifier chip and balanced line drivers. Preamp gain is set by a simple resistor, which can either be a single-turn potentiometer or a 12-step selector switch with the necessary resistor ladder values. The basic stock SK-1DI kit is supplied with the single-turn potentiometer but can be upgraded to use a 12-step selector switch later on. There is also RFI input and output protection, and built-in 48V short-circuit protection to protect the preamp from damage and radio frequency interference.

The SK-1DI uses separate push-button switches for 48V Phantom Power, -20dB Pad, Polarity Reverse, and Mic/DI Input selection. The kit builder can also wire optional 3mm LED indicators for each switch to indicate when the function is enabled.

The SK-1DI also features a built-in DI input for high-impedance instruments like electric guitars, bass guitars, etc. A push-button switch is used to select either Mic-level or DI-input to the unit. A 1/4" TRS jack is provided on the front panel.

The SK-1DI allows the kit builder to install an optional Output Transformer, and a 5-LED VU Meter board. These extra options are not necessary for the preamp's operation, but is provided as an upgrade path. The Output Transformer and 5-LED VU Meter kit are a separate purchase and not part of the basic SK-1DI kit package.

The SK-1DI requires a dual power supply (+/-15V to +/-18 Volts) and +48Volts for phantom power for proper operation.

## 2. TOOLS & EQUIPMENT REQUIRED

A few basic tools and equipment are required to assemble this kit. These basic tools are not supplied with the kit.

- 2.1. Soldering Iron and Lead - We recommend a temperature adjustable soldering iron. **DO NOT USE A 100 WATT SOLDERING GUN.** A small to medium-sized soldering tip is required to solder the small parts. You may use Lead-free or 60/40 lead-based solder.
- 2.2 Cutter - You will need a cutter to cut component leads and wires.
- 2.3. Solder Sucker Pump - If you made a mistake and need to desolder a component, you'll need one.
- 2.4. Multitester - Used for measuring resistance, continuity, and voltages.
- 2.5. Magnifier & Lamp - I recommend a clean and well-lighted space for your assembly area.
- 2.6. Other Tools (not required, but nice to have) - Component lead bender, vise, tweezers, wire stripper.

### 3. ASSEMBLY GUIDE

BEFORE YOU BEGIN: Pick a clean work area where you can leave your work-in-progress unattended if you need to.

Keep individual components in their labeled zip bag until you're ready to solder them. Kit components have been sorted and labeled for your convenience. The labeled components lessens chances of insertion errors, inserting the wrong component into the wrong location. Keeping the components in their zip bags also reduces chance of small parts getting lost or misplaced.

Best practice is to solder the smallest and/or shortest components first. Then solder the taller and larger components next. Big bulkier components like switches, jacks, big capacitors are soldered last.

NOTE: The photos shown on this assembly guide are Rev.1.2 PCBs. Your PCB Revision may be later but assembly instructions are generally the same.



Photo of a finished SK-1DI 500 Series Kit

### 3.1 Solder all 1/4 watt Resistors.

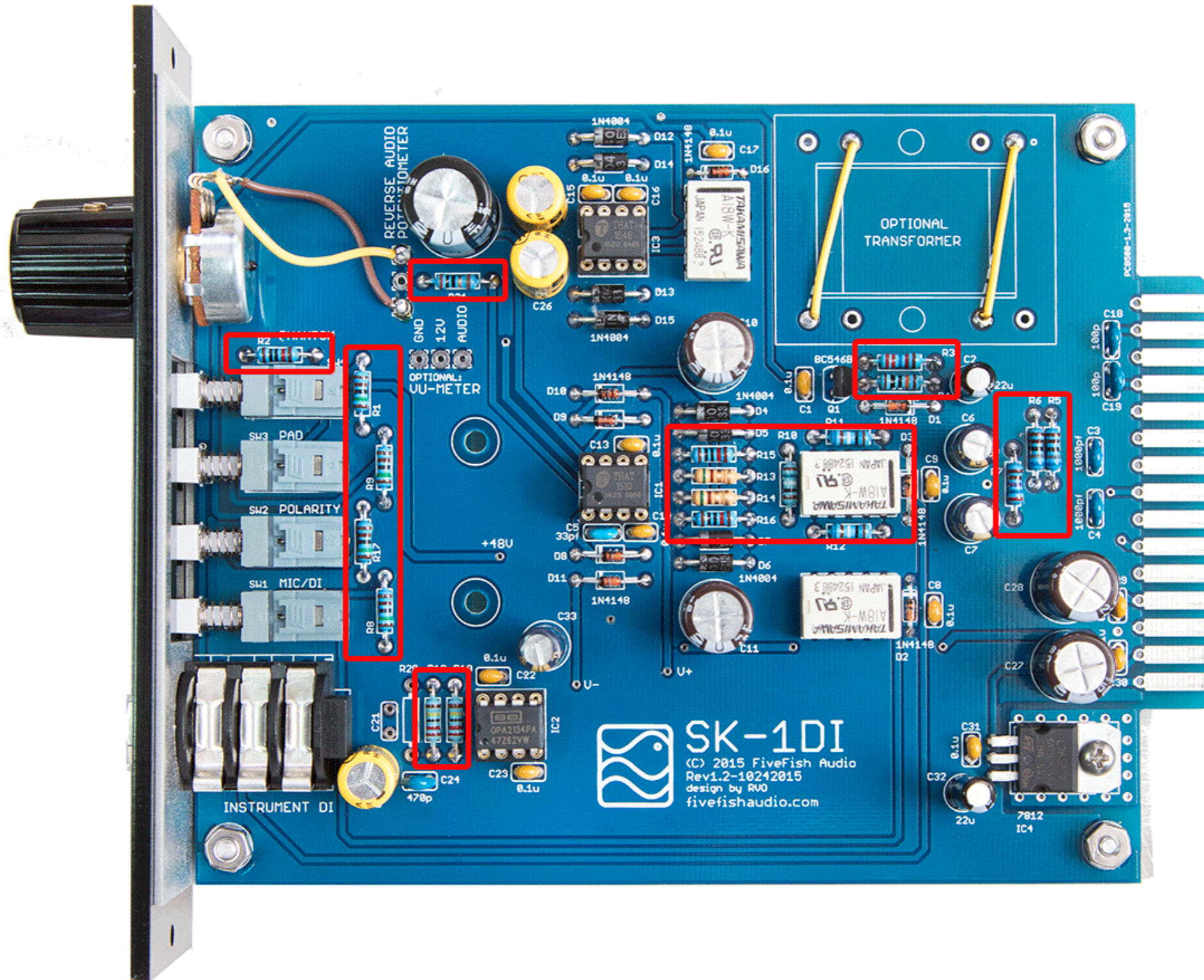



### 3.2 Solder all Signal Diodes and Rectifier Diodes.

**IMPORTANT:** Diodes must be installed in the correct orientation. Observe where the “white band” is located on the board silkscreen marking, and orient the Diodes to follow the same direction.

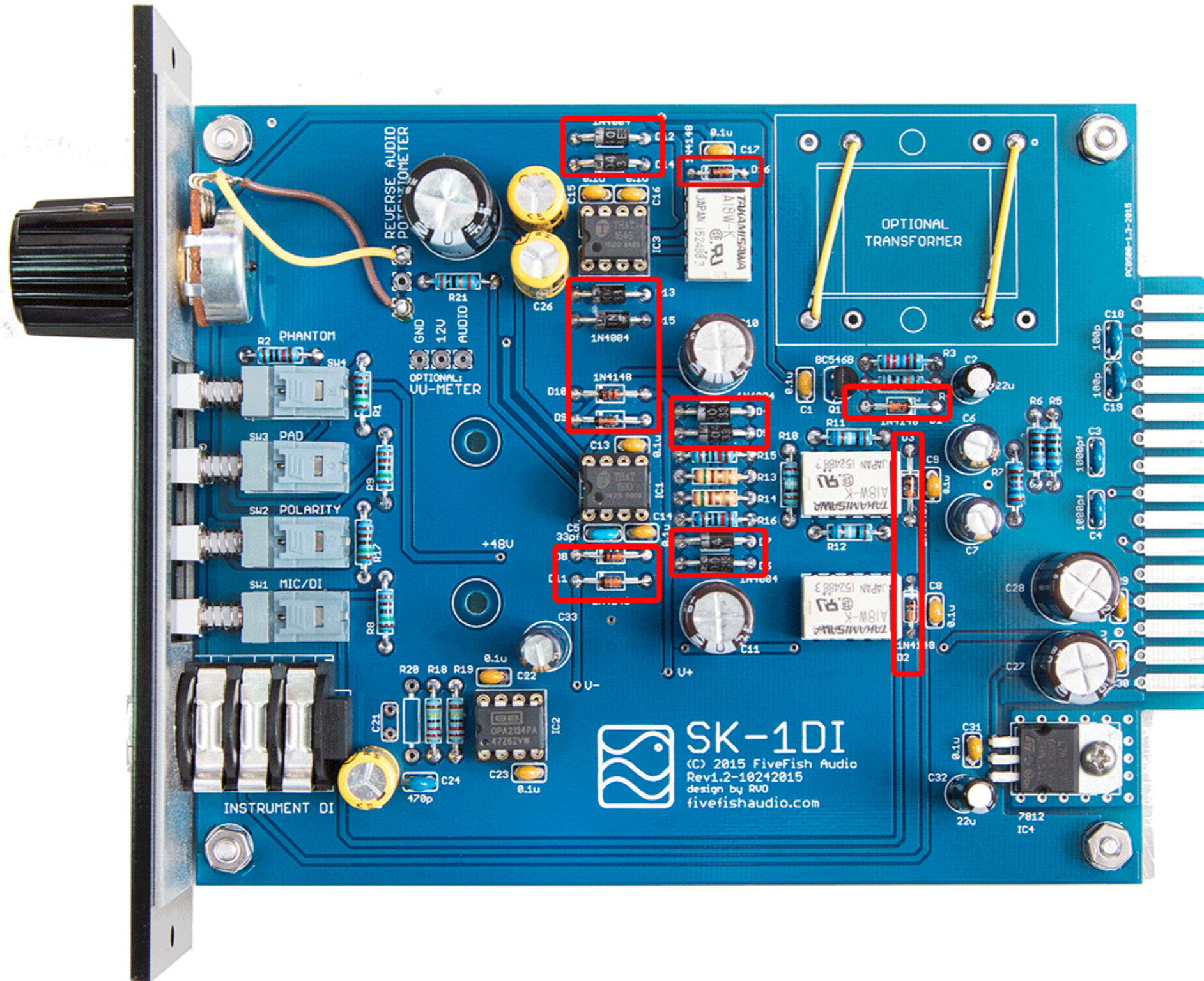

### 3.3 Solder all Ceramic capacitors.

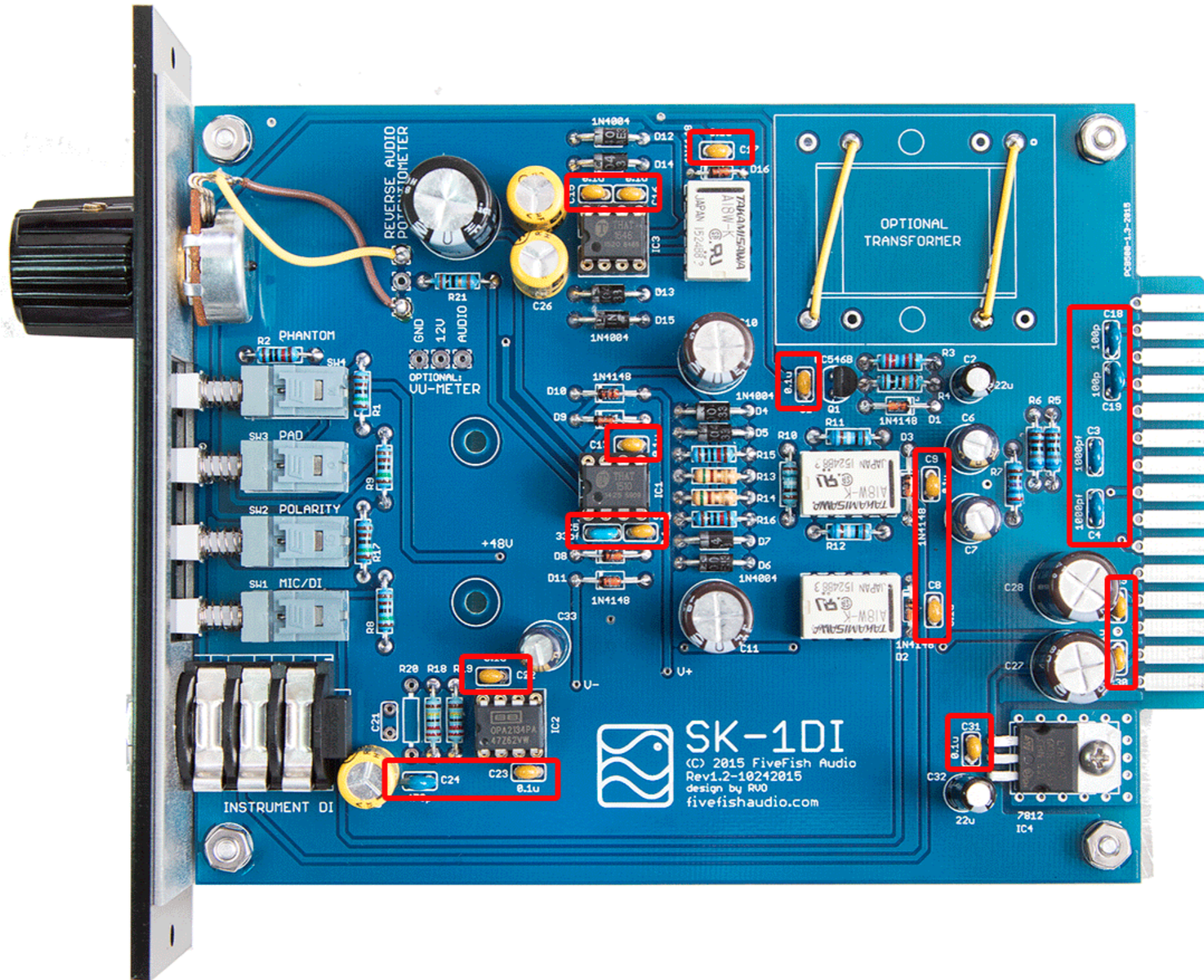

### 3.4 Solder the (3) IC Sockets.

TIP: One side of the IC socket will have a notch. Position this notch on the left-side for use as a guide for Pin1 location.

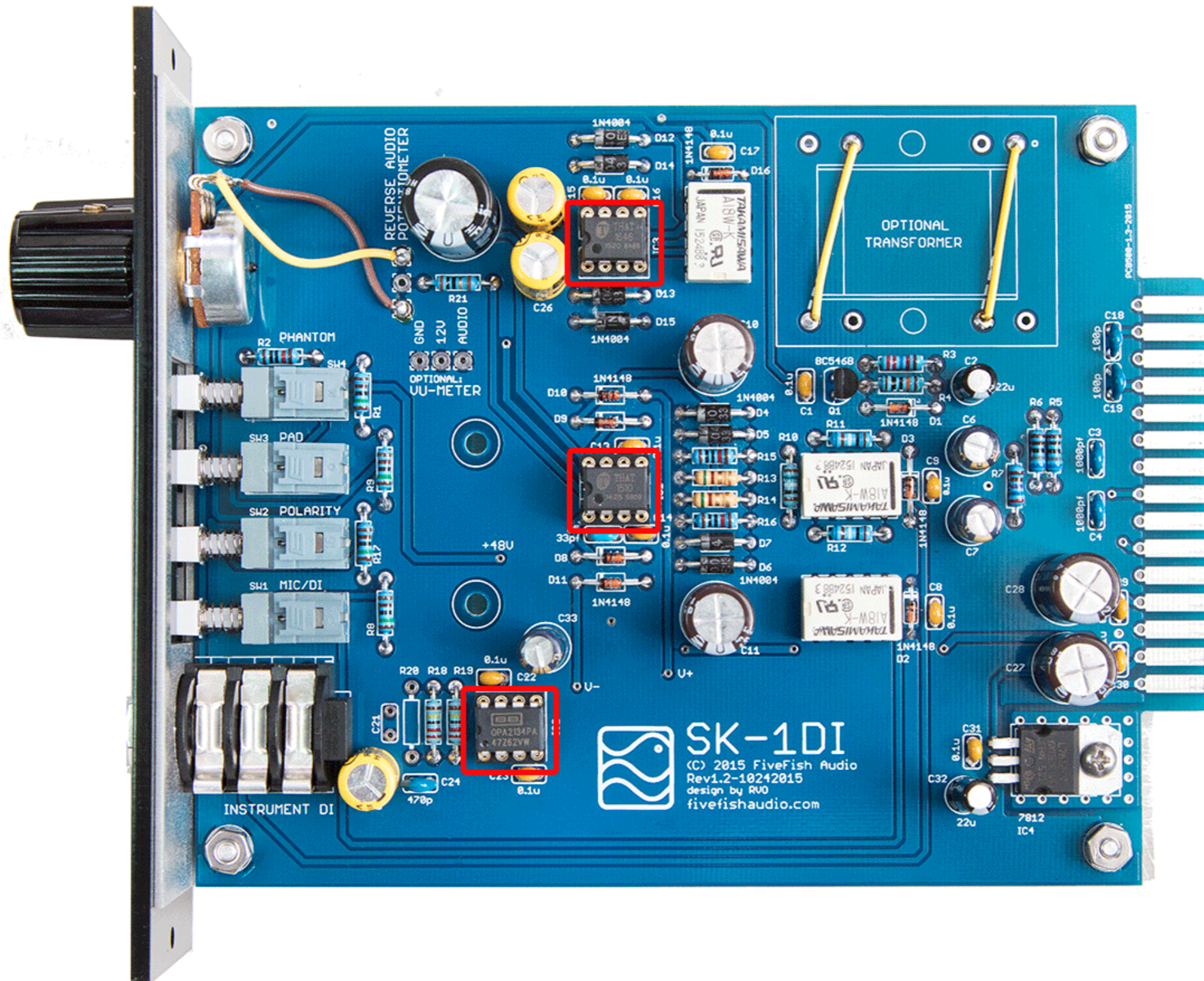

3.5 Solder the (3) PDIP Relays. Take note of the Relay part number that came with your kit and follow the next step.  
**IMPORTANT:** Insert Relays in proper orientation. Match the “white band” on PCB silkscreen with the Relay’s line markings.

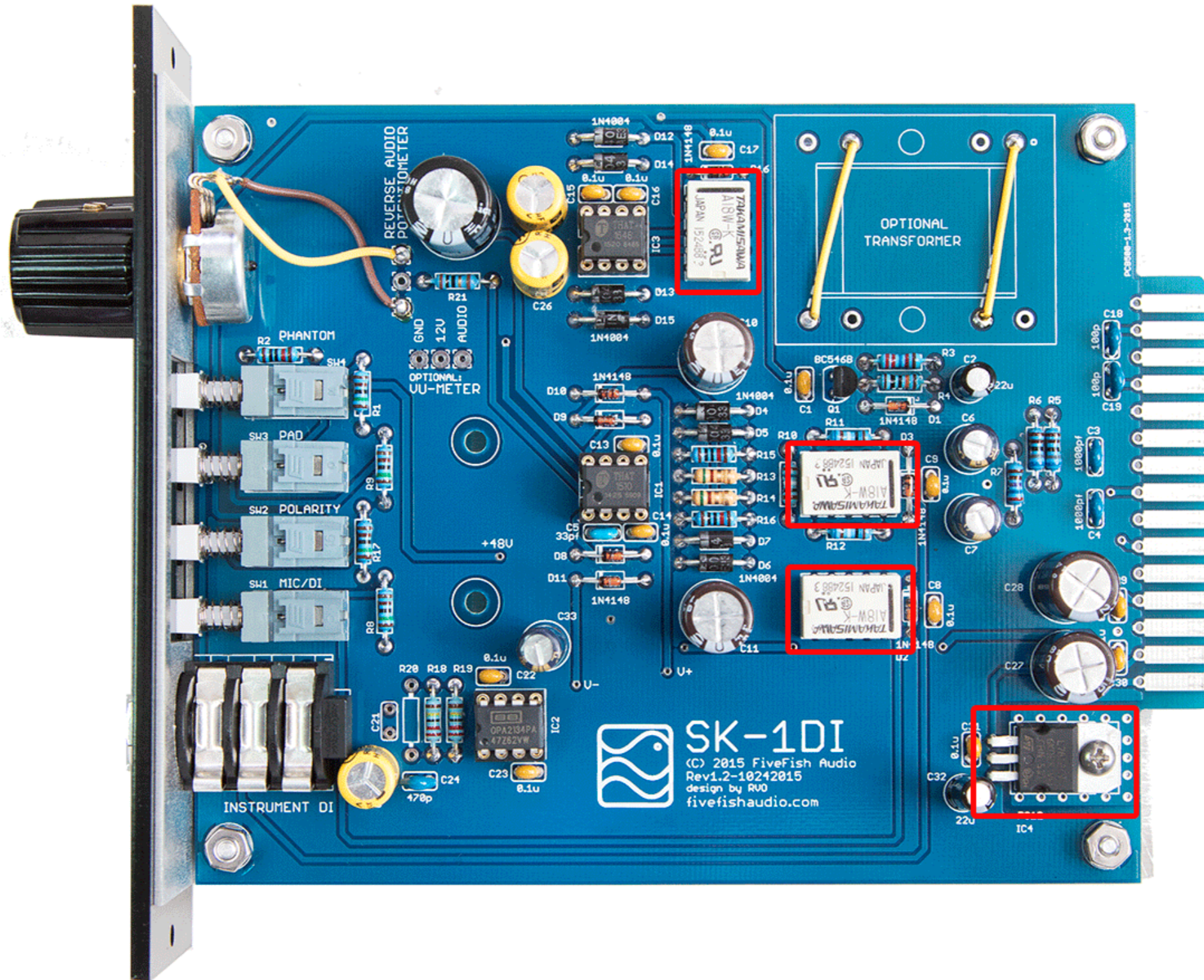

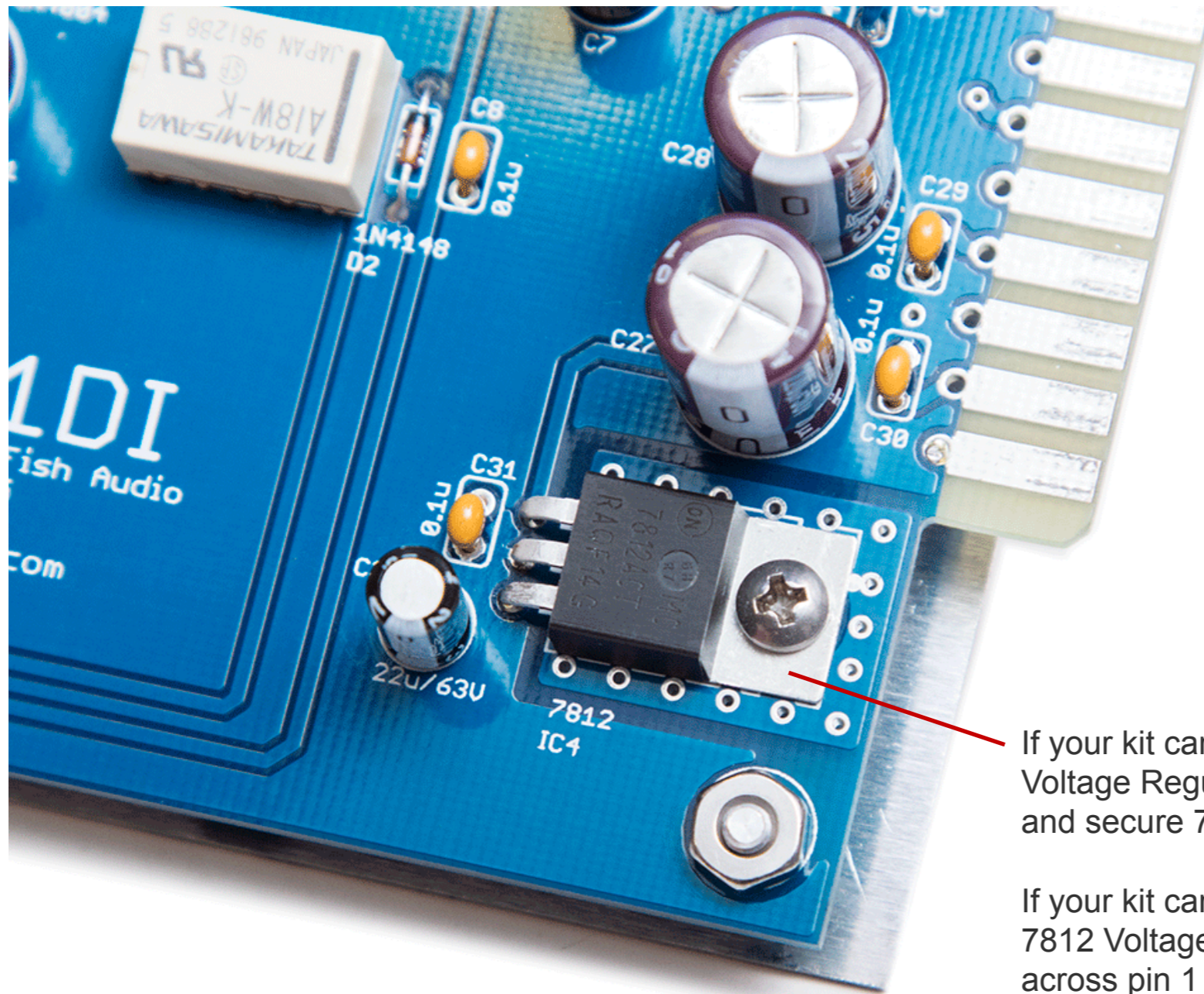

If your kit came with A12W-K Relays, solder the 7812 Voltage Regulator at IC4 location. Bend the legs as shown and secure 7812 metal tab with machine screw and nut.

If your kit came with A18W-K Relays, Do NOT install the 7812 Voltage Regulator. Instead, solder a JUMPER wire across pin 1 and pin 3 of IC4 location.

Note: Photos on this guide show A18W-K relays with a 7812 Regulator also installed. This combination will also work, but the 7812 Regulator is not really necessary in this case.

3.6 Solder the (3) Bi-polar capacitors. These capacitors have no polarity and can be inserted either way.

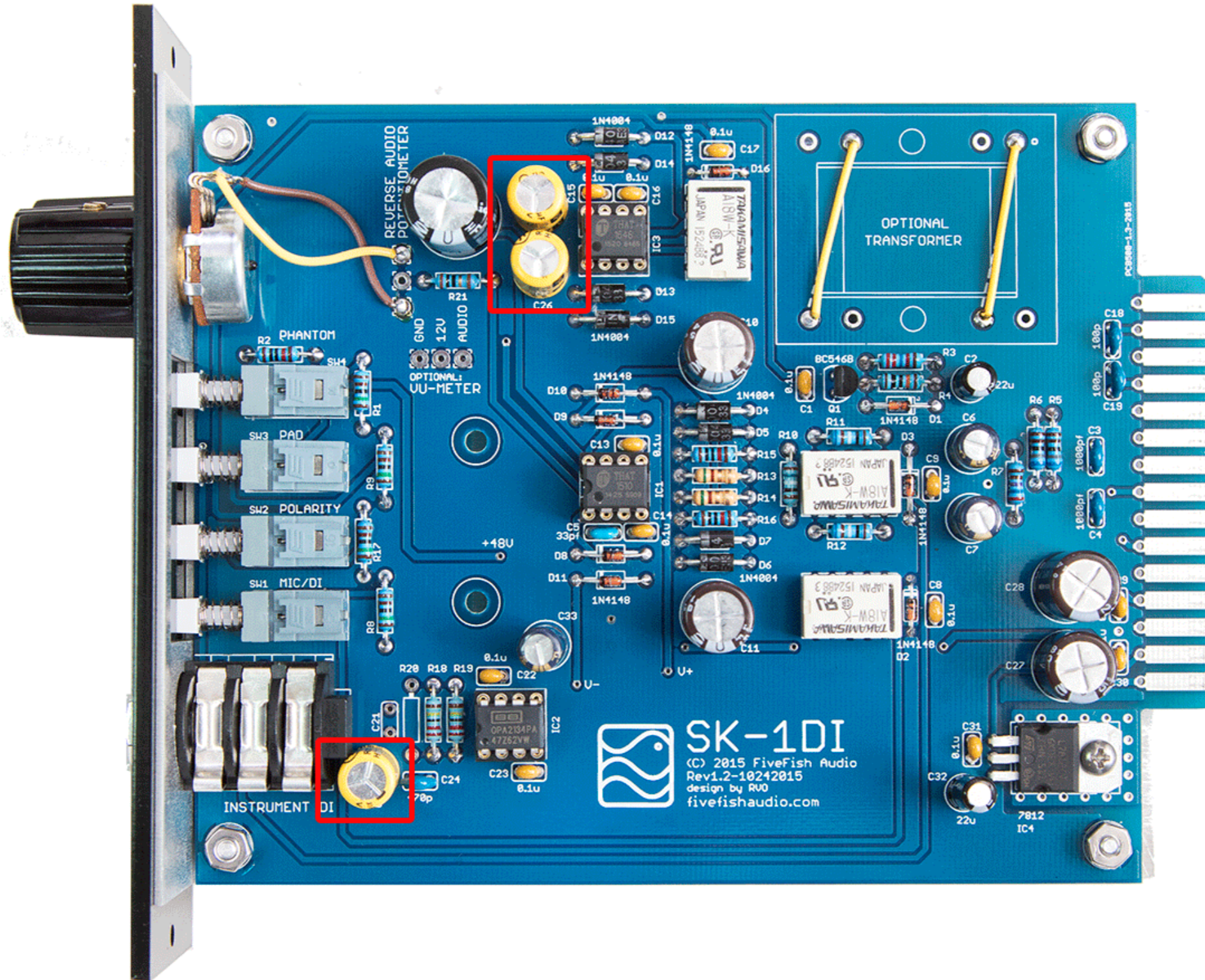

3.7 Solder all small Electrolytic Capacitors. These capacitors have polarity markings, one lead is (+) and the other lead is (-). **IMPORTANT:** Observe the proper polarity when inserting these capacitors. Match polarity with PCB silkscreen markings. All negative (-) leads of electrolytic capacitors are orientated facing downwards.

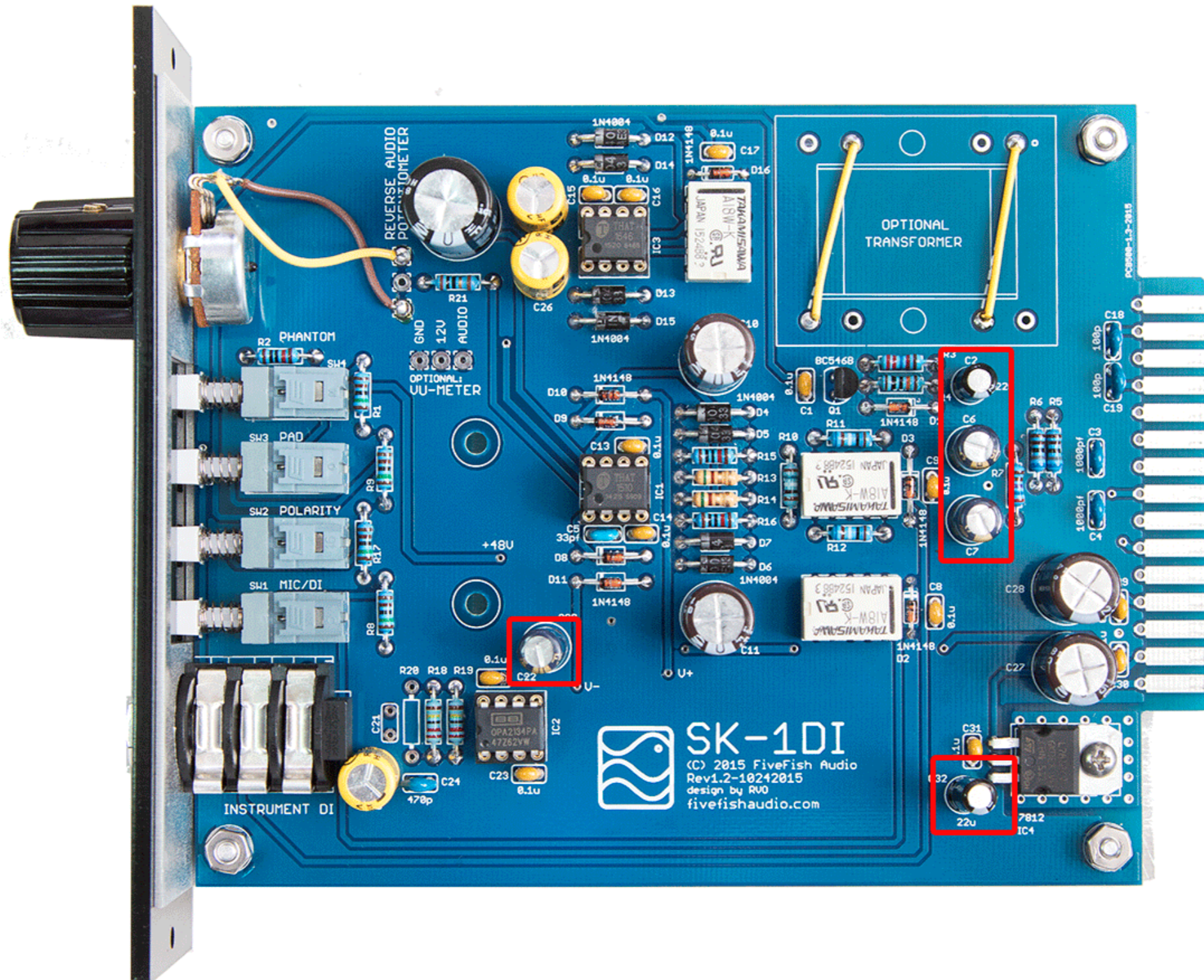

### 3.8 Solder Q1 Transistor.

**IMPORTANT:** Observe proper orientation and the direction transistor is facing. Follow the PCB silkscreen markings.

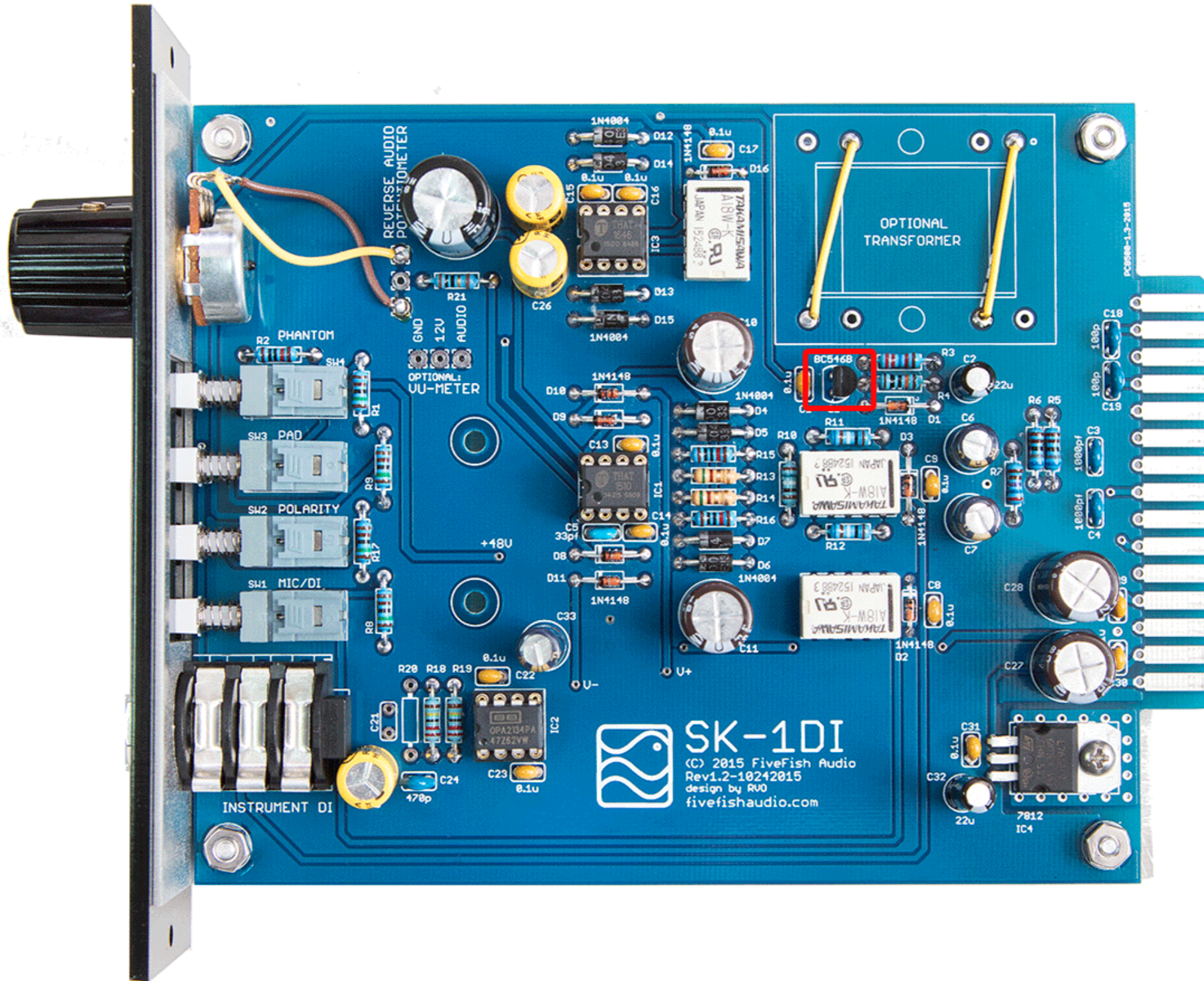



3.9 Solder all 3mm LED indicator lamps from bottom of board. These LED lamps are optional and not required. You can arrange the LED colors any way you want. But for consistency, use the same color arrangement on all mic preamp kits you'll build.

**NOTE: LEDs are installed from the bottom.  
Bend LED legs as shown on photos.**

NOTE: PCB Rev.1.2 does **\*NOT\*** need the jumper wire shown in the photo below.

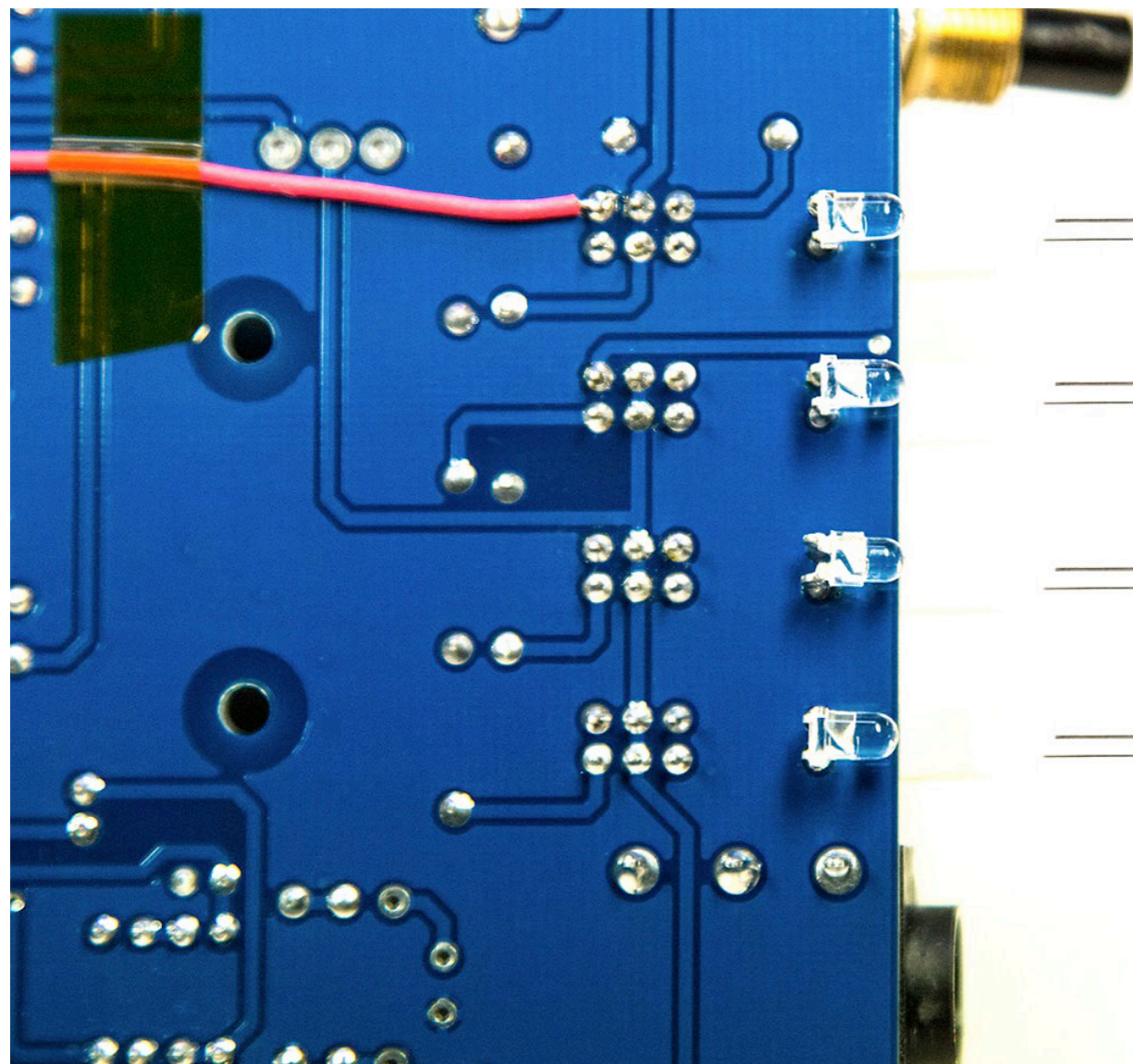
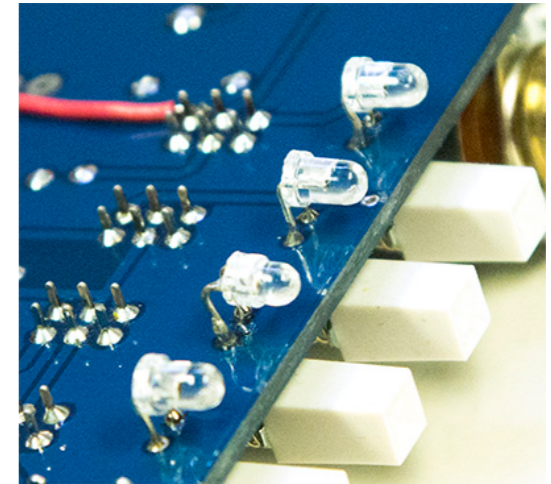

A typical color arrangement may be

- GREEN** - for phantom power switch,
- BLUE** - for 20dB Pad,
- YELLOW** - for polarity reverse,
- RED** - for Mic/Instrument selector switch.

**IMPORTANT: The LONG LEG of the LED must be oriented at the BOTTOM position as shown.**

3.10 Drill (4) holes on the aluminum sled if you want to use the LED indicator lamps. Position the LEDs so they are aligned with the drilled holes on your aluminum sled. You can use anywhere from a 1/16" hole up to 1/8" hole size. The larger drill hole size means alignment is less critical.

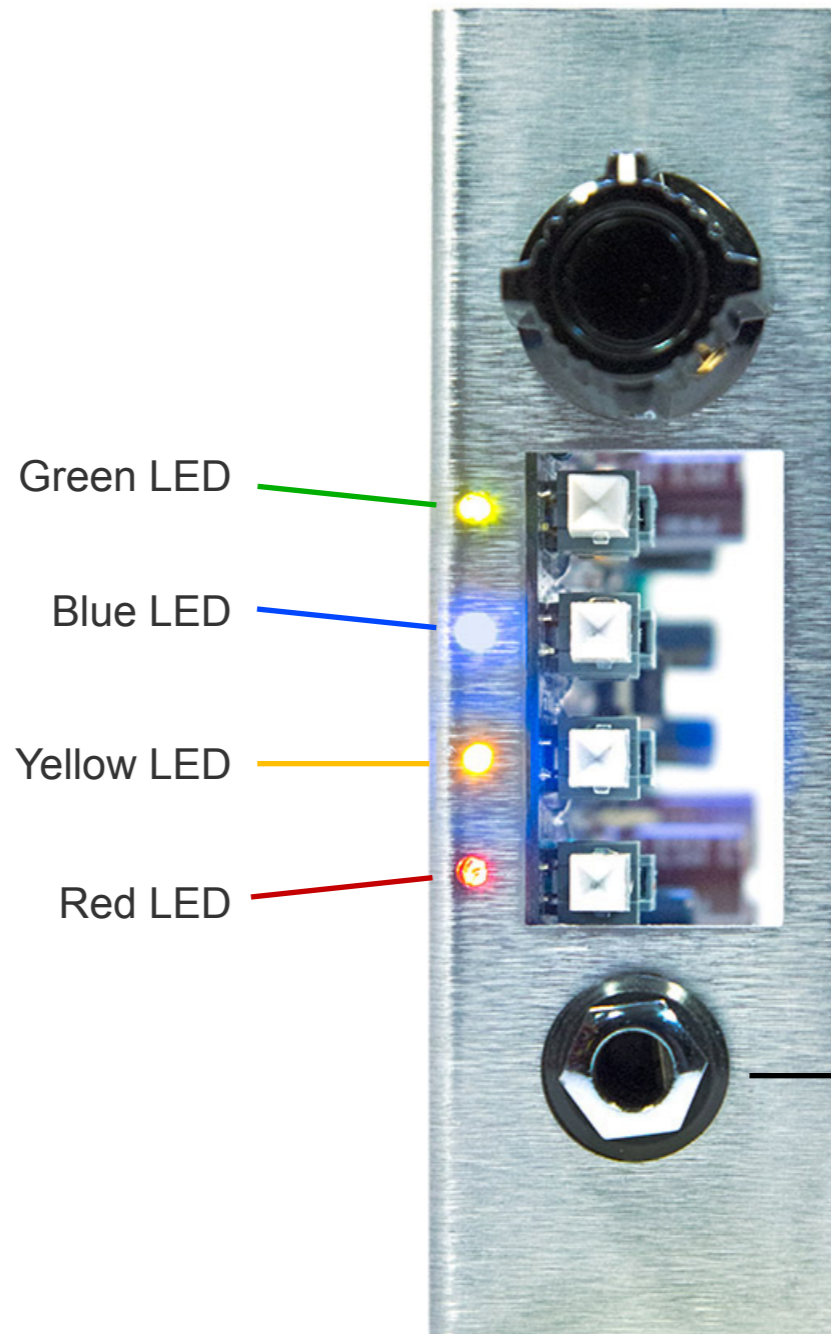

Smaller sized holes look better as they're not too overpowering bright when lit up.

NOTE: The LEDs are mounted at the bottom of the PCB.

You will also need to enlarge the hole on the aluminum sled for the 1/4" TRS jack.

- 3.11 Solder the (4) Push-Button switches. Make sure they're mounted horizontally level and not crooked or mis-aligned. TIP: You may use masking tape to hold the switch secure in it's place while you solder. Solder only one of the switch terminals and review if the switch is still horizontally level. If everything looks good, solder the rest of the switch terminals.

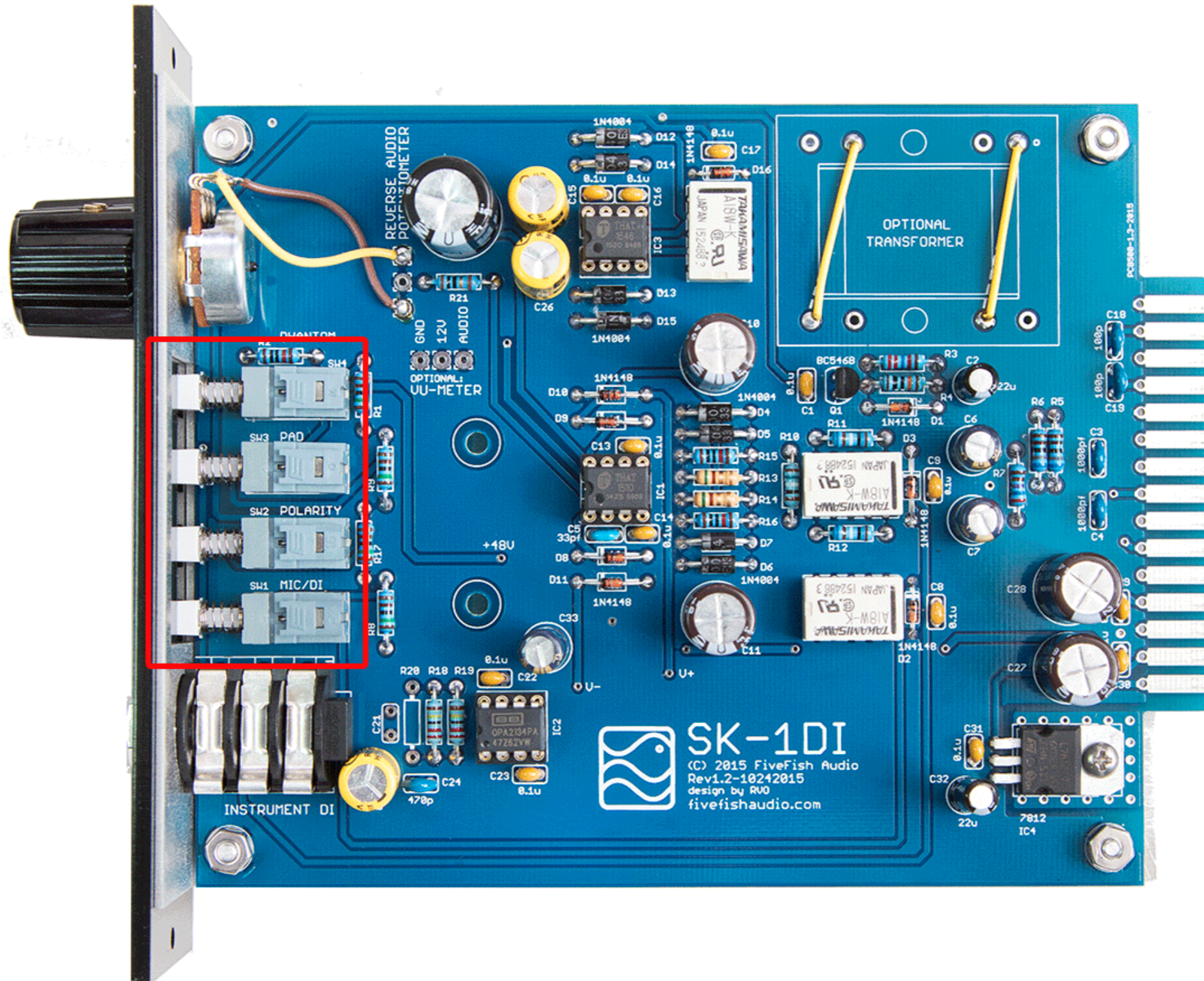

3.12 Solder all medium-sized 220uf electrolytic capacitors.

**IMPORTANT:** Observe proper polarity and orientation of (+) and (-) leads.

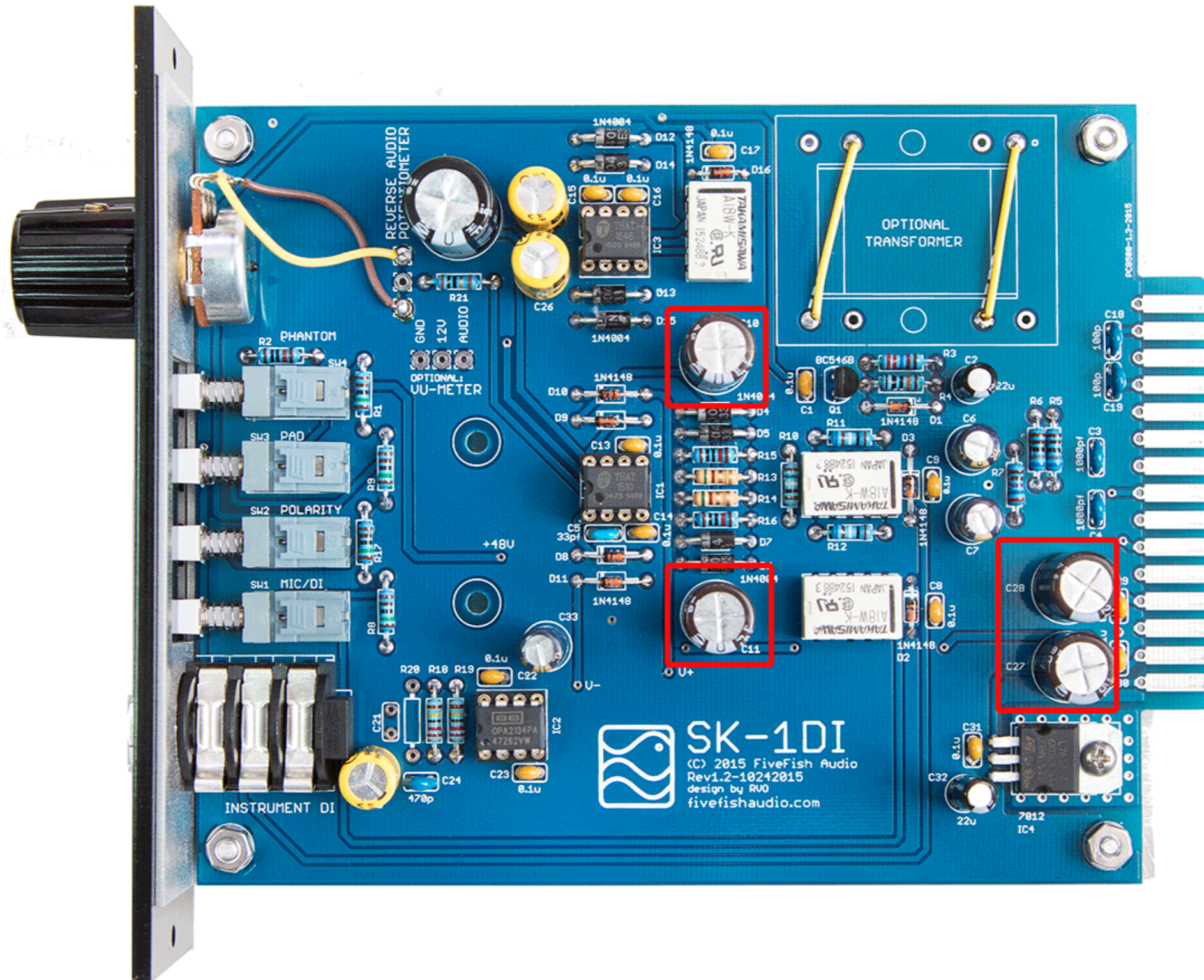

3.13 Solder C12, 3300uf capacitor. This capacitor is required if using a rotary potentiometer for Gain control.

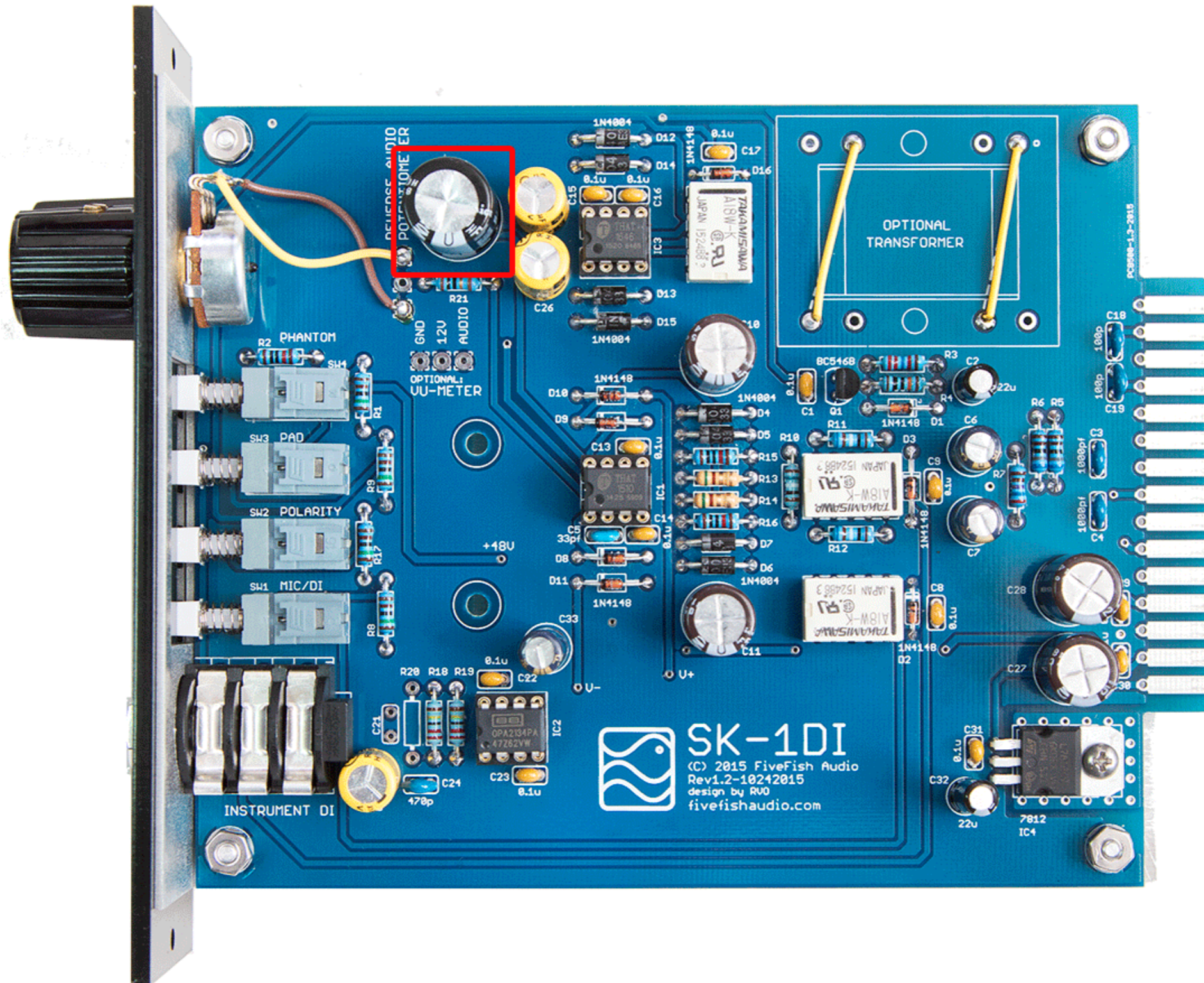

3.14 Solder the 1/4" TRS Instrument Jack. Make sure to mount TRS jack level and flat as possible with the PCB. You may need to push the TRS jack down to be flat as possible, then solder the legs.

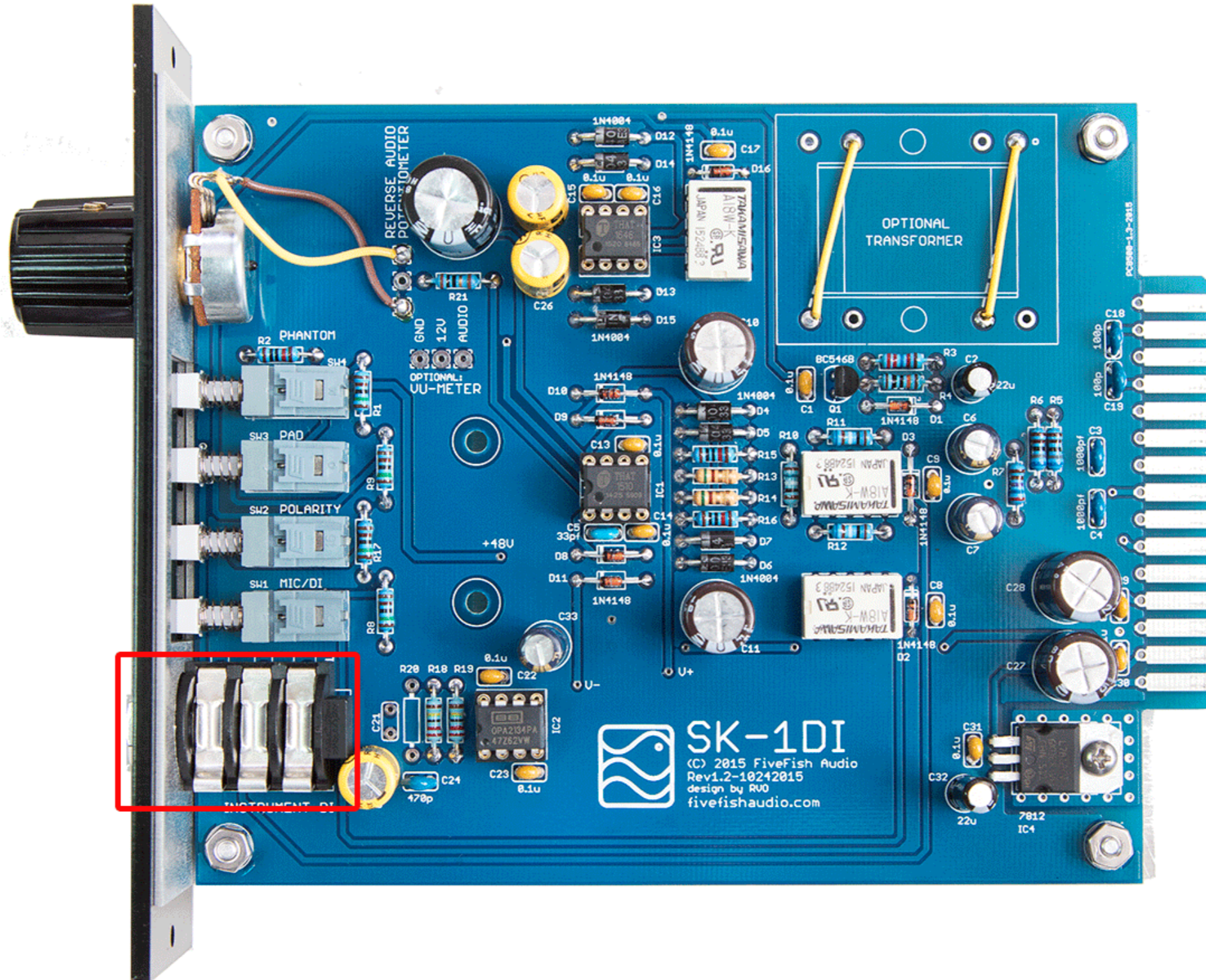

3.15 Solder the 10K Potentiometer as shown below. Use a couple short pieces of wire to connect potentiometer to the board.

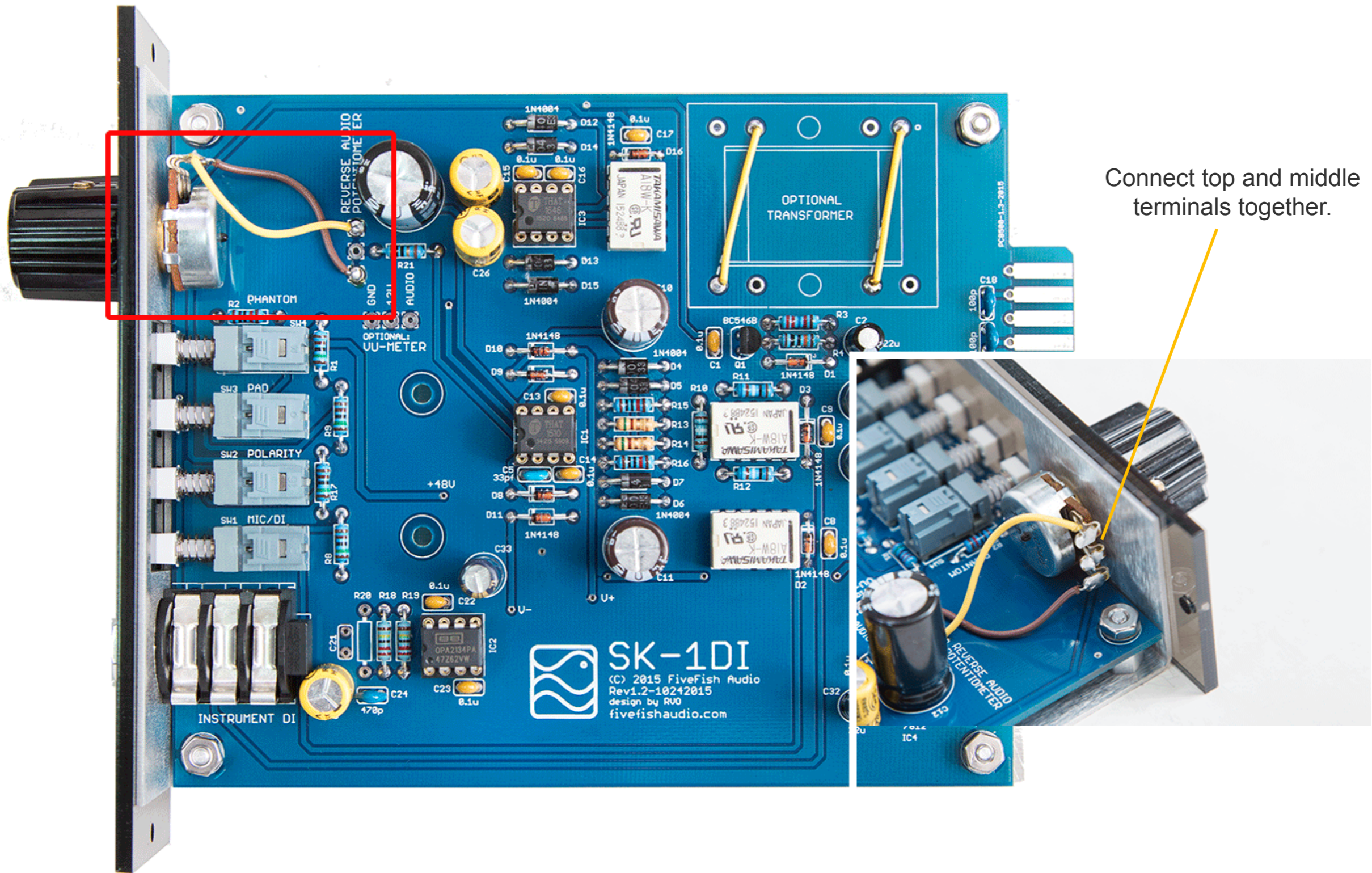

### 3.16 Install the optional Output Transformer.

IMPORTANT: If not using an Output Transformer, solder jumper wires instead as shown below:

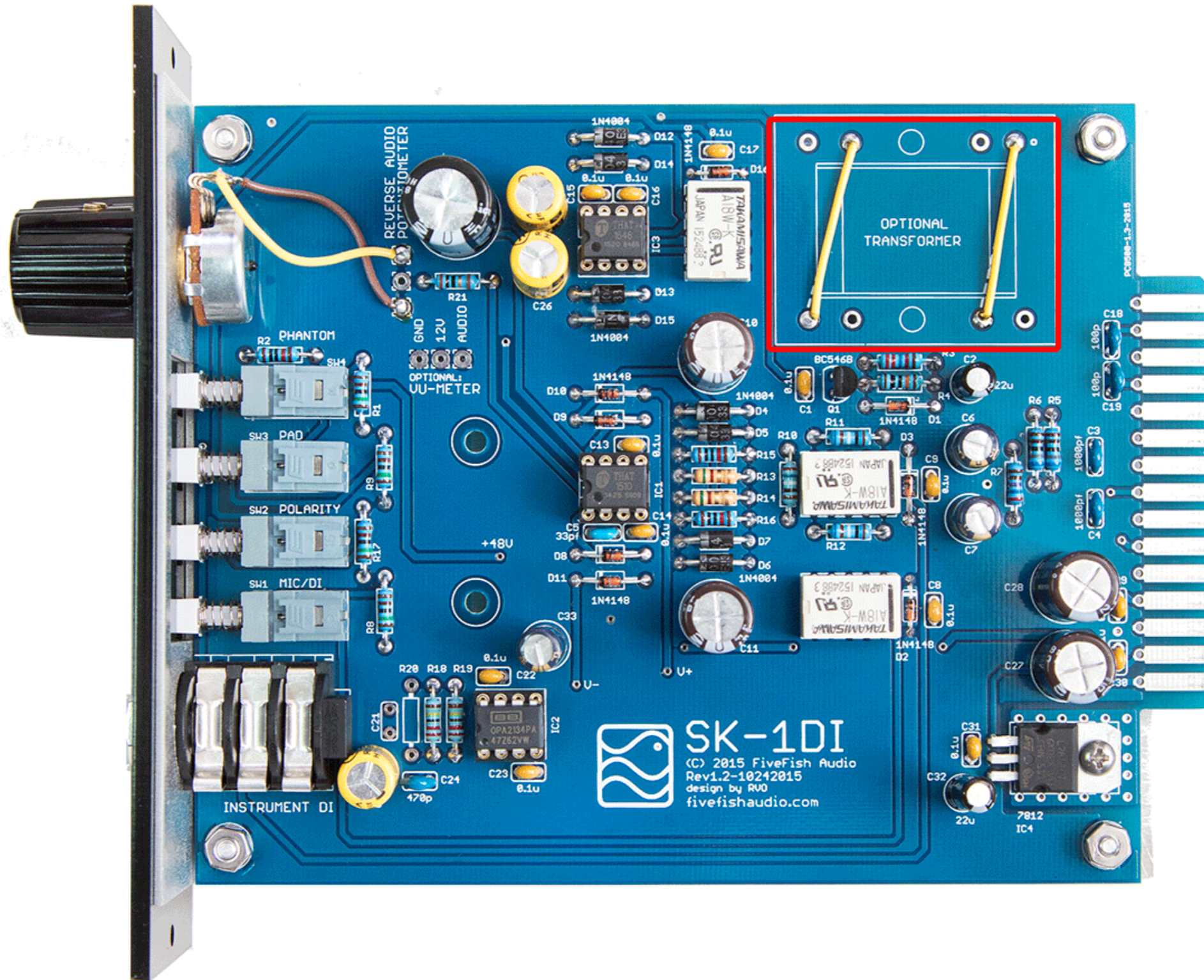



3.17 NOTE: This step is not required for PCB Rev.1.2

This page intentionally left blank.

3.18 NOTE: This step is not required for PCB Rev.1.2

This page intentionally left blank.

3.19 NOTE: This step is not required for PCB Rev.1.2

This page intentionally left blank.

3.20 OPTIONAL: Assemble and mount the VU Meter kit. Solder the GND, V+ and Audio wires between VU Meter Board and SK-1DI Mic Preamp Board.

NOTICE: Currently, the VU Meter kit cannot be used with the Acrylic Front Panel (unless you drill (5) additional 1/8" holes for the LEDs). The Anodized Aluminum Front Panel upgrade will have the necessary holes for the VU Meter LEDs.

If there is enough requests for VU Meters for use with the Acrylic Front Panel, we will create an alternate Acrylic Front Panel design with the VU Meter LED holes. So let us know what you think!

**NOTE: If you have PCB Rev1.00 and wish to install the VU METER KIT, Please contact us for an EXCLUSIVE OFFER!**

3.21 Install mounting spacers to PCB using the Aluminum Male-Female Hex Spacers and 4-40 nuts. Then mount PCB to aluminum sled using the provided small screws.

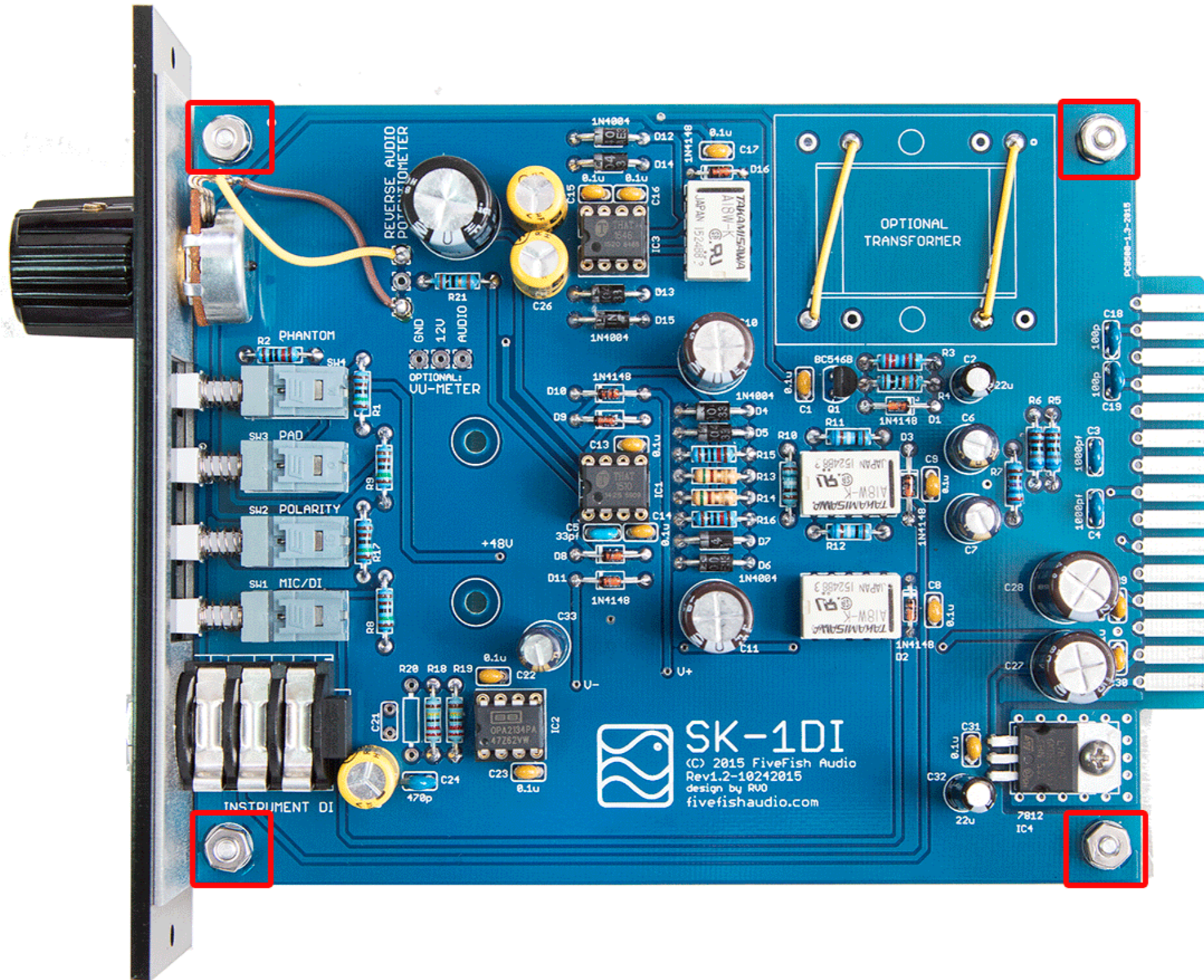

3.22 Attach the transparent acrylic front panel. Tighten nuts of potentiometer and 1/4" TRS jack. Then install knobs. **IMPORTANT:** Do not overtighten nuts to avoid damaging the Acrylic Front Panel.

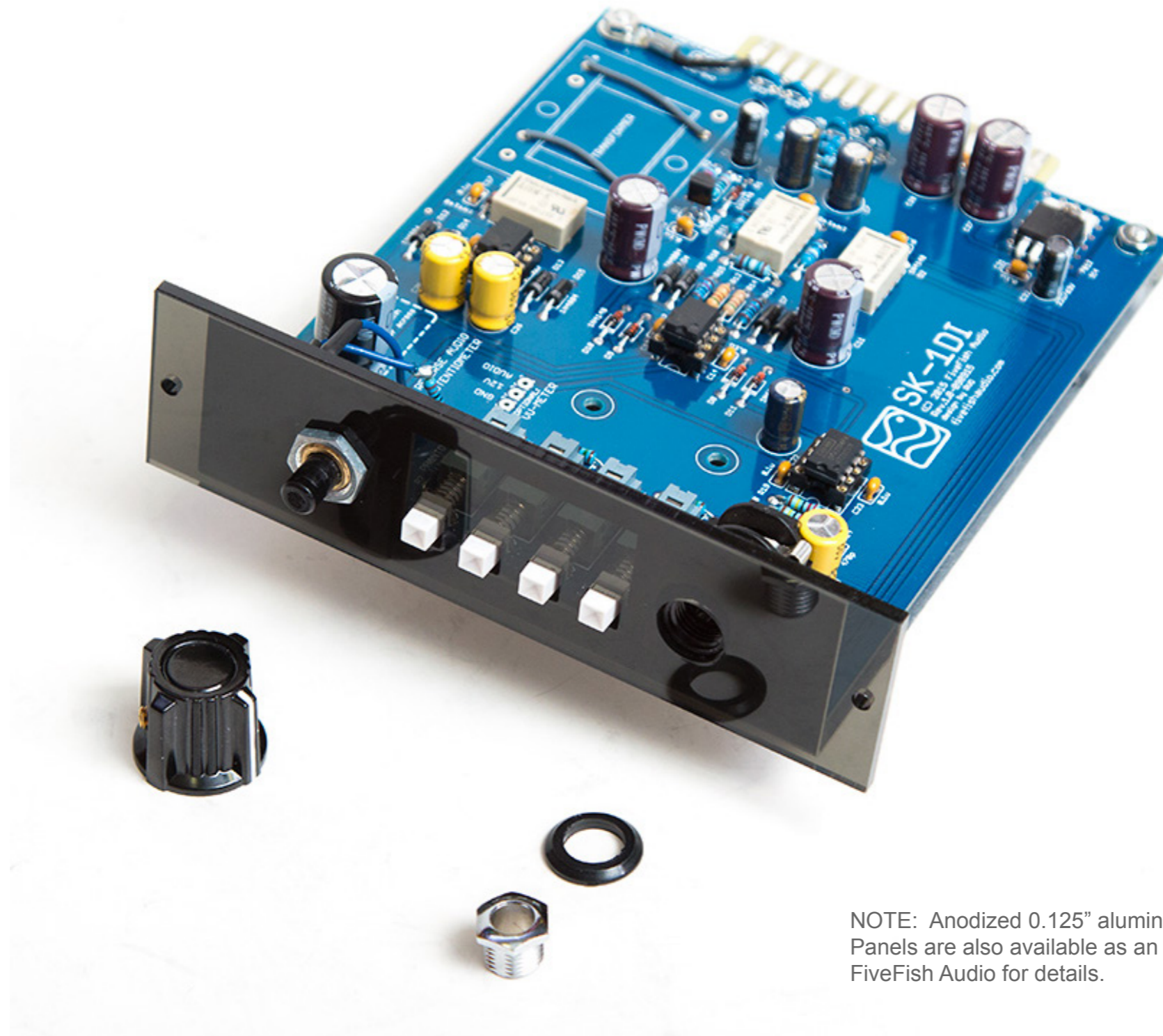

NOTE: Anodized 0.125" aluminum CNC-engraved Front Panels are also available as an upgrade option. Contact FiveFish Audio for details.

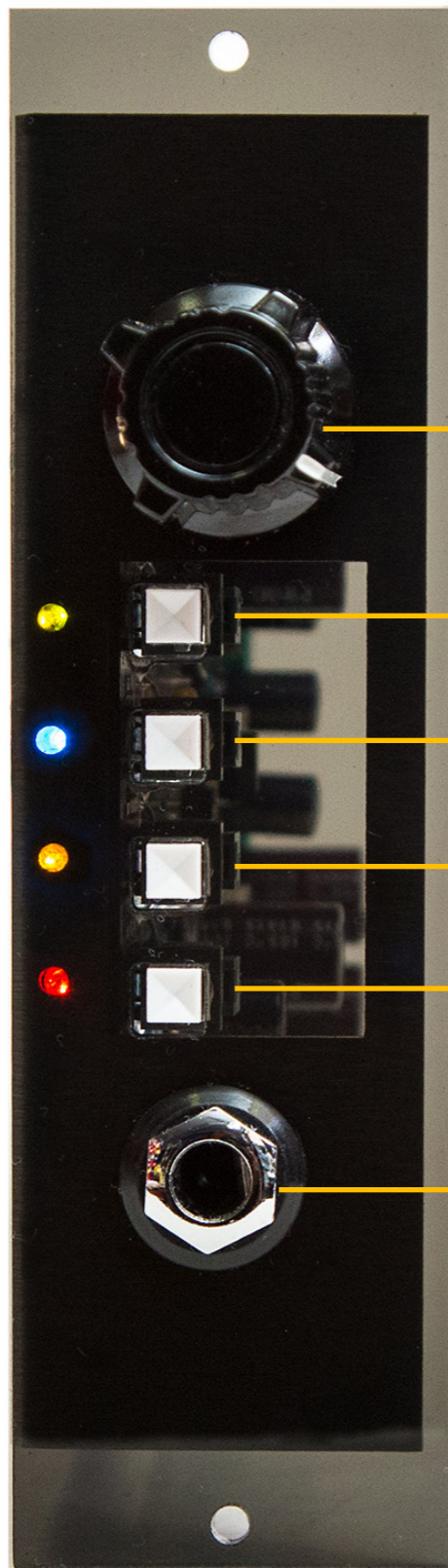

Gain Control

48V Phantom Power

-20dB Pad

Polarity Reverse

Mic/Instrument DI Select

1/4" Instrument Input

NOTE: SK-1DI Kit comes with a 3mm Transparent Gray Acrylic front panel.  
The lighted LEDs show through very nicely through the tinted transparent front panel.

3.23 Finally, insert the (3) IC chips into their IC sockets. IC1 = THAT 1510; IC2 = OPA2134; IC3 = THAT 1646

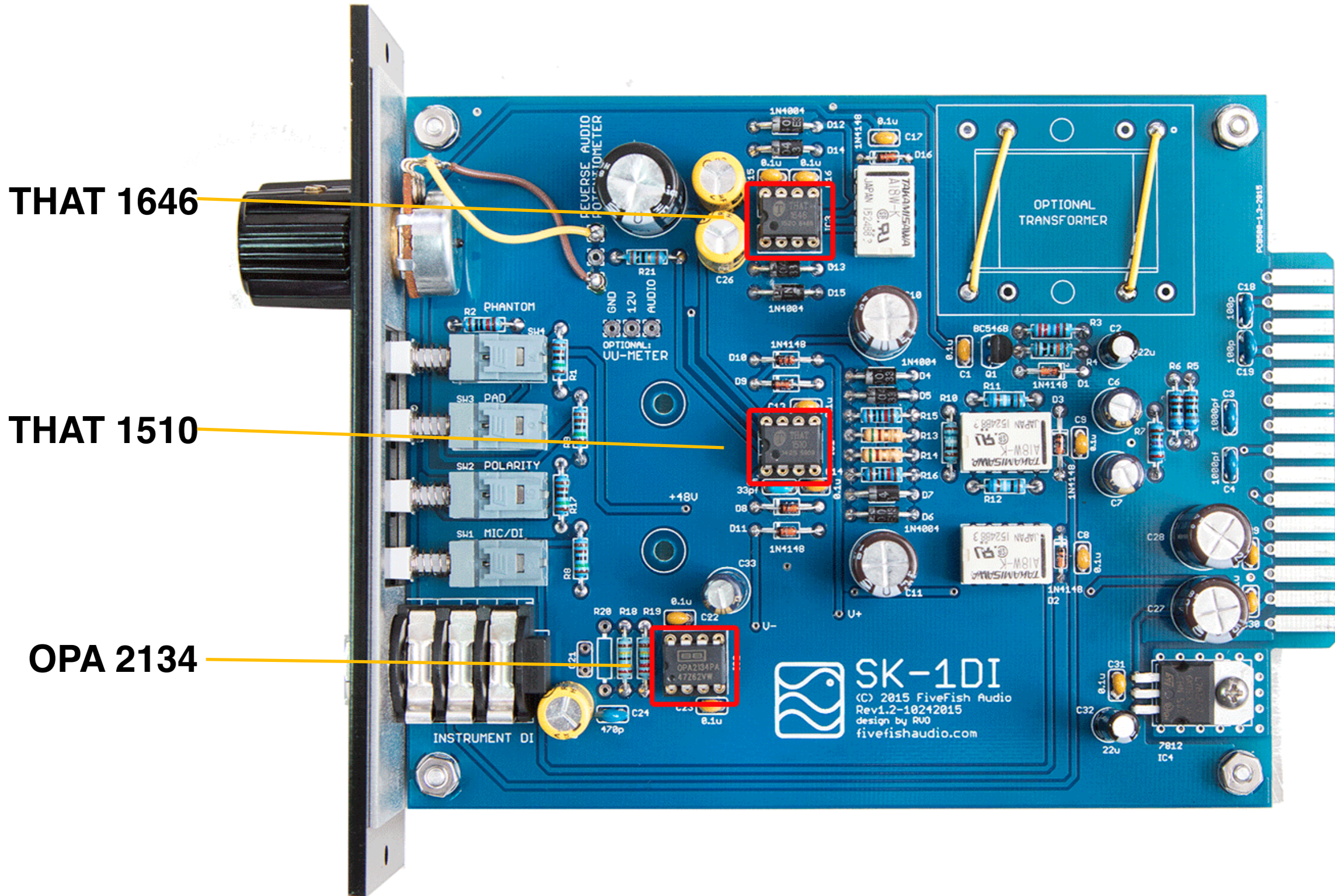



3.24 OPTIONAL: If you purchased the Gain Selector Switch Adapter Board, follow these additional steps.

3.24.1 Solder the (12) resistors using the PCB Component Guide below.

3.24.2 Solder the Grayhill selector switch.

3.24.3 Wire the Switch Adapter Board as shown in the photo below.

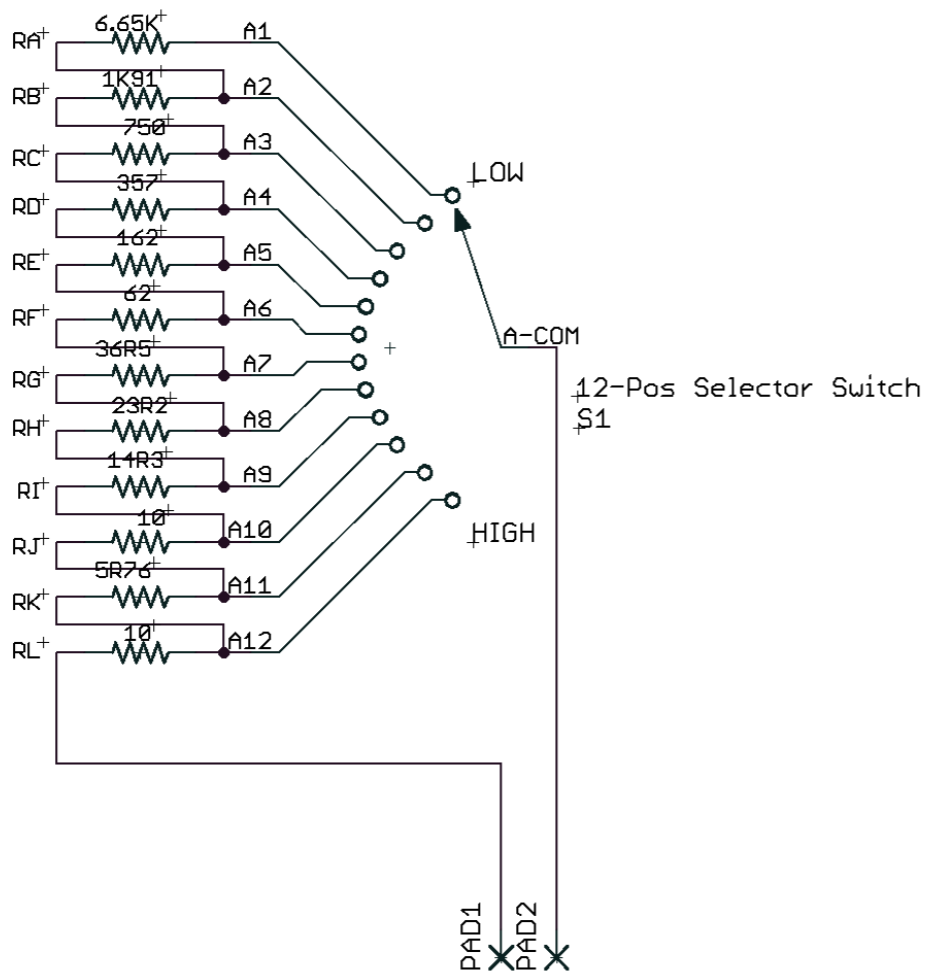

Schematic Diagram

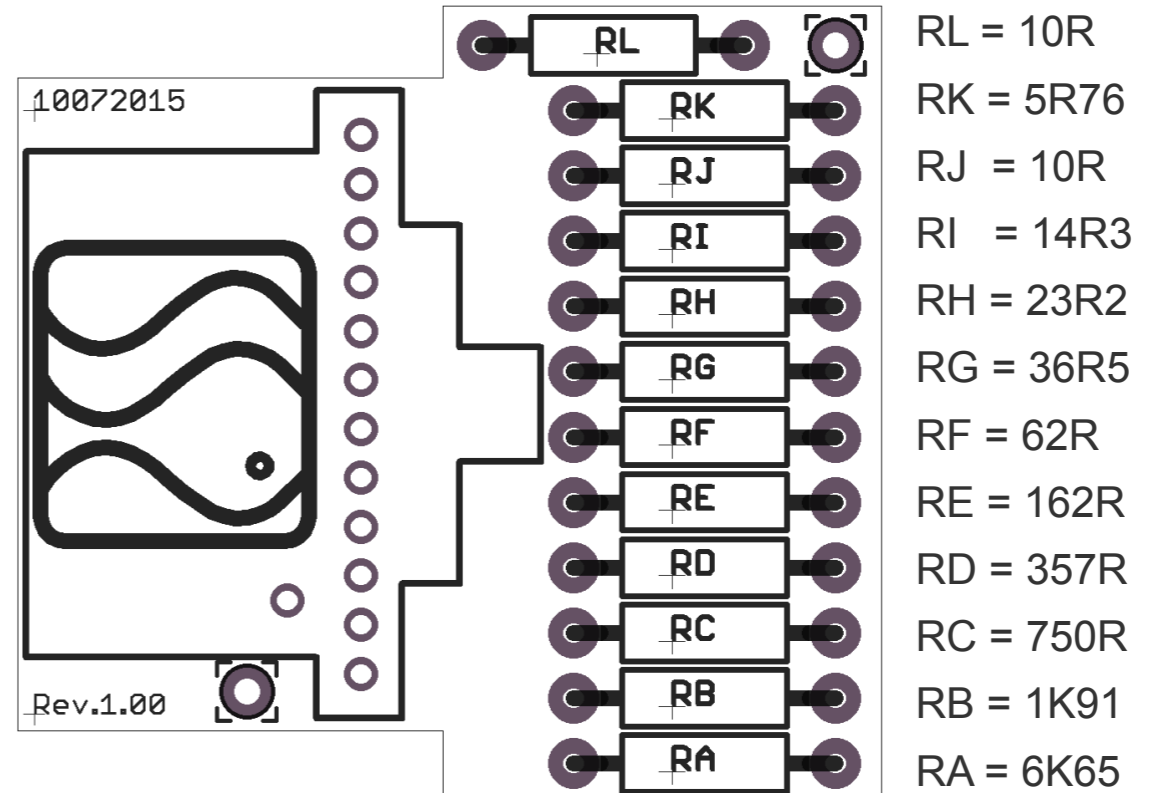

PCB Top View

- RL = 10R
- RK = 5R76
- RJ = 10R
- RI = 14R3
- RH = 23R2
- RG = 36R5
- RF = 62R
- RE = 162R
- RD = 357R
- RC = 750R
- RB = 1K91
- RA = 6K65

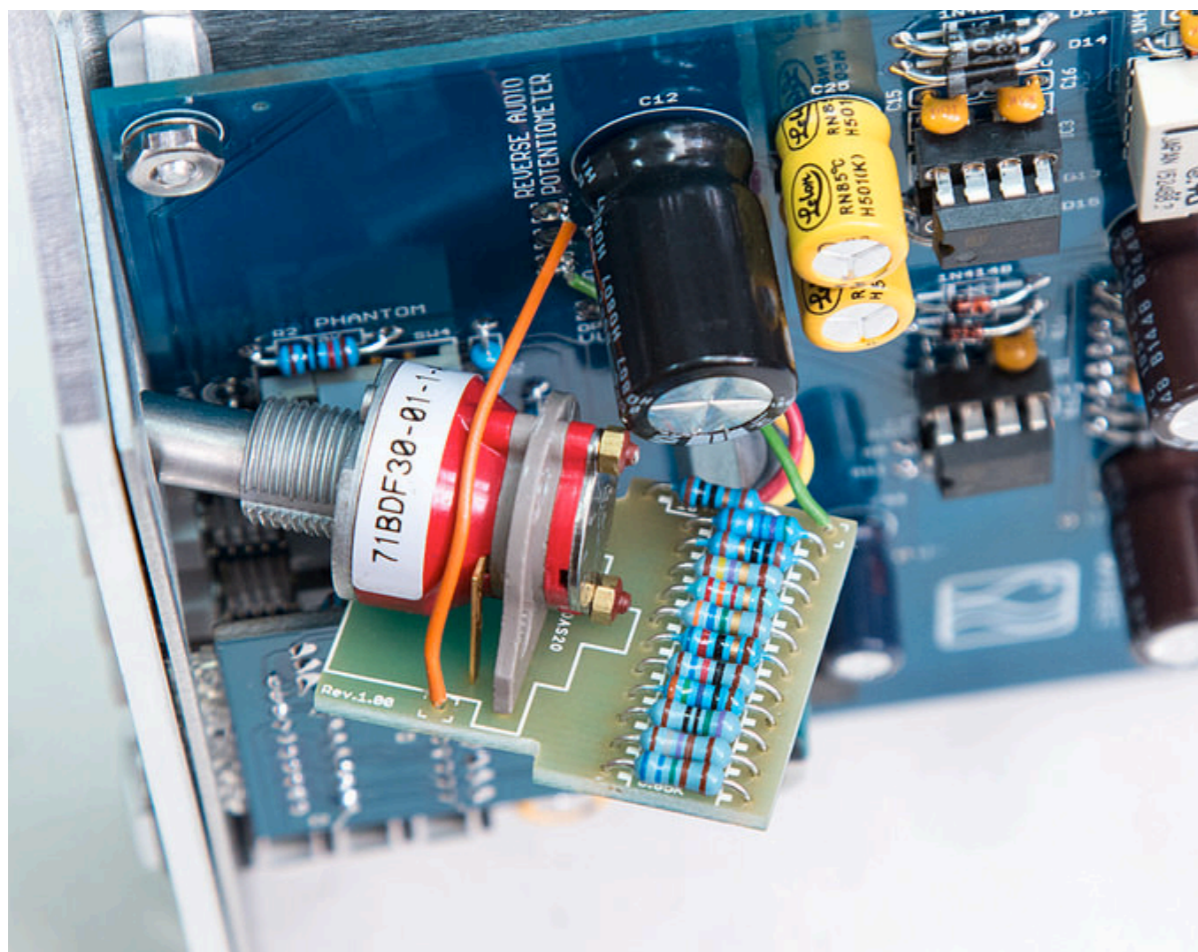

Wire the Switch Board as shown above. “Orange” wire goes to topmost pad on preamp board. “Green” wire goes to bottom pad on preamp board. (Of course, you may use your own colored wires. Above is just an example for illustration purposes.)

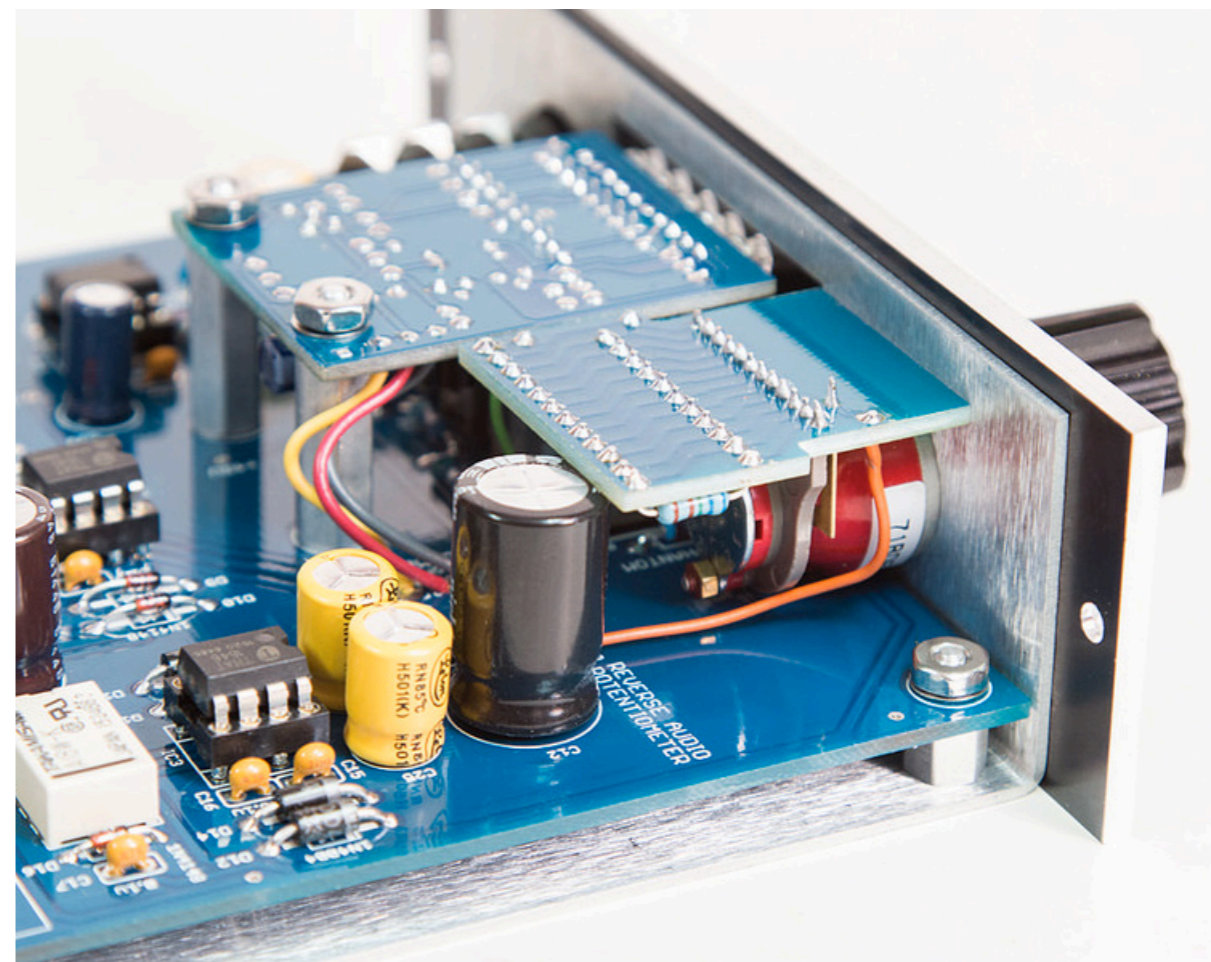

The Switch Board needs to be installed upside down as shown in photo above. Tighten nut when done installing board. (Also shown in photo above is the optional VU Meter Board.)

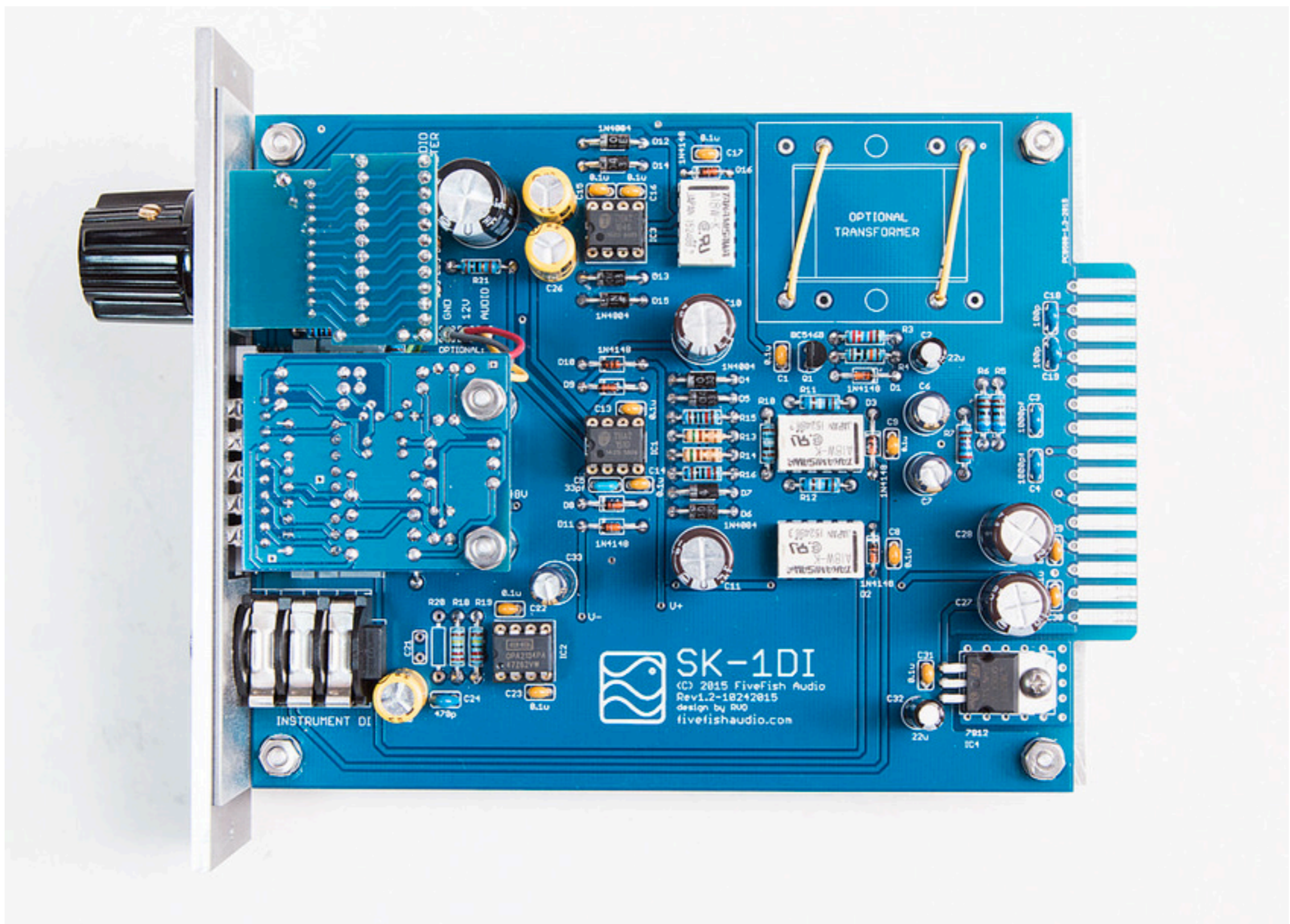

Photo of SK-1DI Preamp showing optional Switch Board and VU Meter board installed.

## 4. ERRATA / MANUAL CHANGE INFORMATION

Yay! No errata for PCB Rev.1.2

This page intentionally left blank.

## 5. PRE-FLIGHT CHECK

Before applying power to the unit, please review your work one last time.

Go over Step 3, and in particular review the following specific items:

- 5.1 Perform a visual inspection. Check for any cold solder joints, or short circuit bridges.
- 5.2 Check if all diodes are installed in correct orientation.
- 5.3 Check if all polarized electrolytic capacitors are installed in correct orientation.
- 5.4 Check if all relays are installed in correct orientation.
- 5.5 Check if jumper to bypass IC4 is required (only required if using A12W-K Relays).
- 5.6 Check if jumper wires are required for Output Transformer location (if not using an Output Transformer).
- 5.7 Check if IC1, IC2, and IC3 are inserted in their correct locations and oriented correctly.

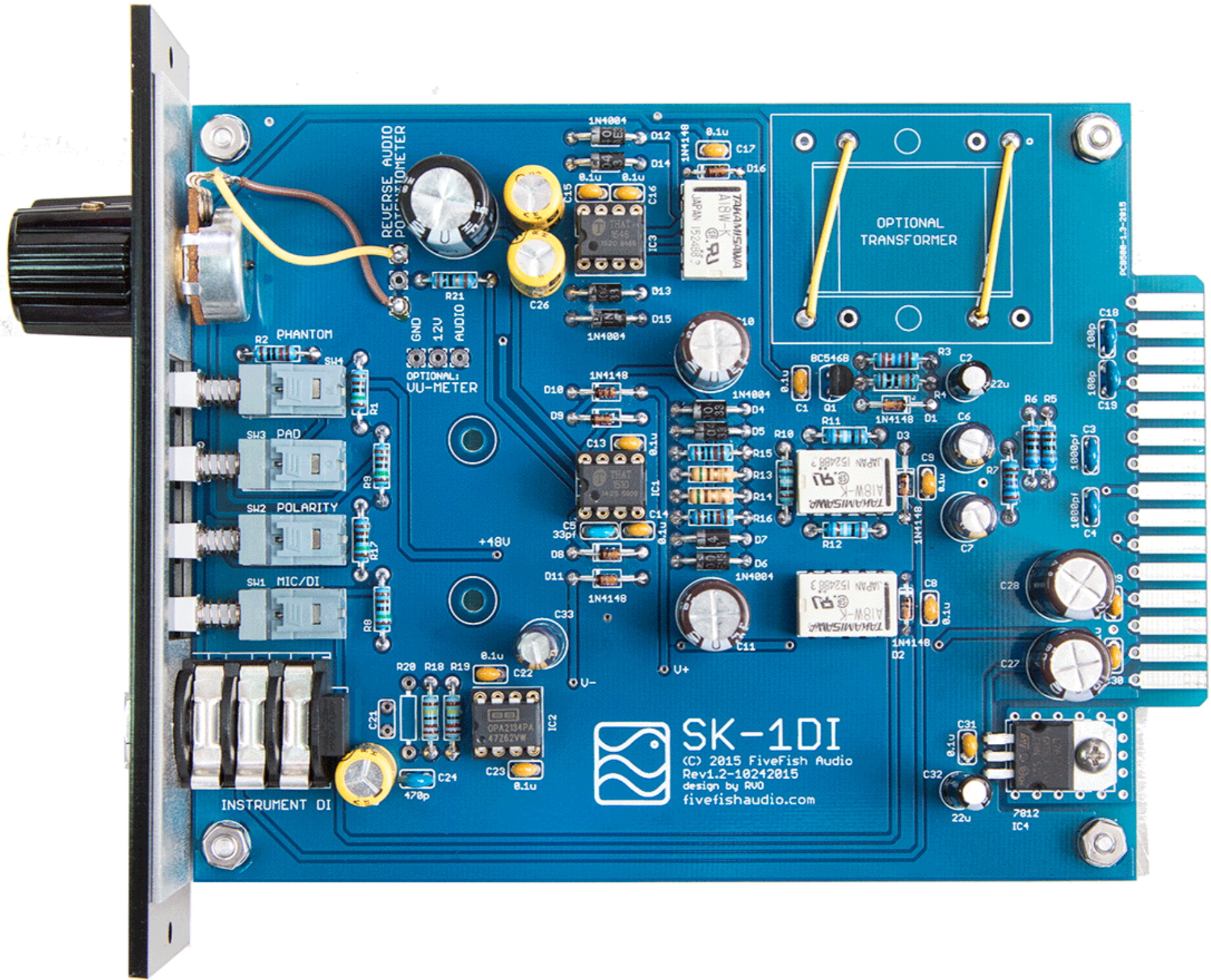

## 6. PARTS LIST

PART REFERENCE	QTY	VALUE
<b>PCB</b>	1	SK-1DI 500-series PCB
<b>CAPACITORS</b>		
C3, C4,	2	1000pf 50V
C5	1	33pf / 50V
C24	1	470pf 50V
C6, C7, C33	3	47uf / 50V
C1, C8, C9, C13, C14, C15, C16, C17, C22, C23, C29, C30, C31	13	0.1uf / 100V
C20, C25, C26	3	10uf / 50V NON-POLAR
C18, C19	2	100pf / 50V
C10, C11, C27, C28	4	220uf / 50V
C2, C32	2	22uf / 63V
C12	1	3300uf / 10V
<b>SEMICONDUCTORS</b>		
D4, D5, D6, D7, D12, D13, D14, D15	8	1N4004
D1, D2, D3, D8, D9, D10, D11, D16	8	1N4148
LED1, LED2, LED3, LED4	4	GREEN, BLUE, YELLOW, RED
IC1	1	THAT 1510
IC2	1	OPA2134P
IC3	1	THAT 1646
IC4	1	7812
Q1	1	BC546B NPN transistor



<b>All resistors 1/4 watt, metal film when available</b>		
R7	1	2K67
R5, R6	2	6K8
R13, R14	2	5R1
R2, R15, R16	3	10K
R4	1	100K
RPOT	1	10K REV AUDIO POT
R3	1	22K6
R18, R19	2	2M2
R1, R8, R9, R17	4	1K5
R10	1	169R
R11, R12	2	619R
R21	1	10R
<b>HARDWARE</b>		
TRS JACK	1	TRS JACK, PCB MOUNT
RLY1, RLY2, RLY3	3	RELAY
IC1, IC2, IC3 SOCKETS	3	8P IC SOCKET
SW1, SW2, SW3, SW4	4	PB, DPDT, MTH-2-2U
ALUMINUM SLED - MACHINED	1	ALUMINUM SLED
HEX SPACER FOR SLED	4	HEX .187X.250 ALUM M/F
4-40 NUT	4	FOR ALUMINUM SLED
UNDERCUT MACHINE SCREW	4	FOR ALUMINUM SLED
4-40 x 1/4" MACHINE SCREW	1	FOR 7812 REGULATOR

# 7. SCHEMATIC DIAGRAM

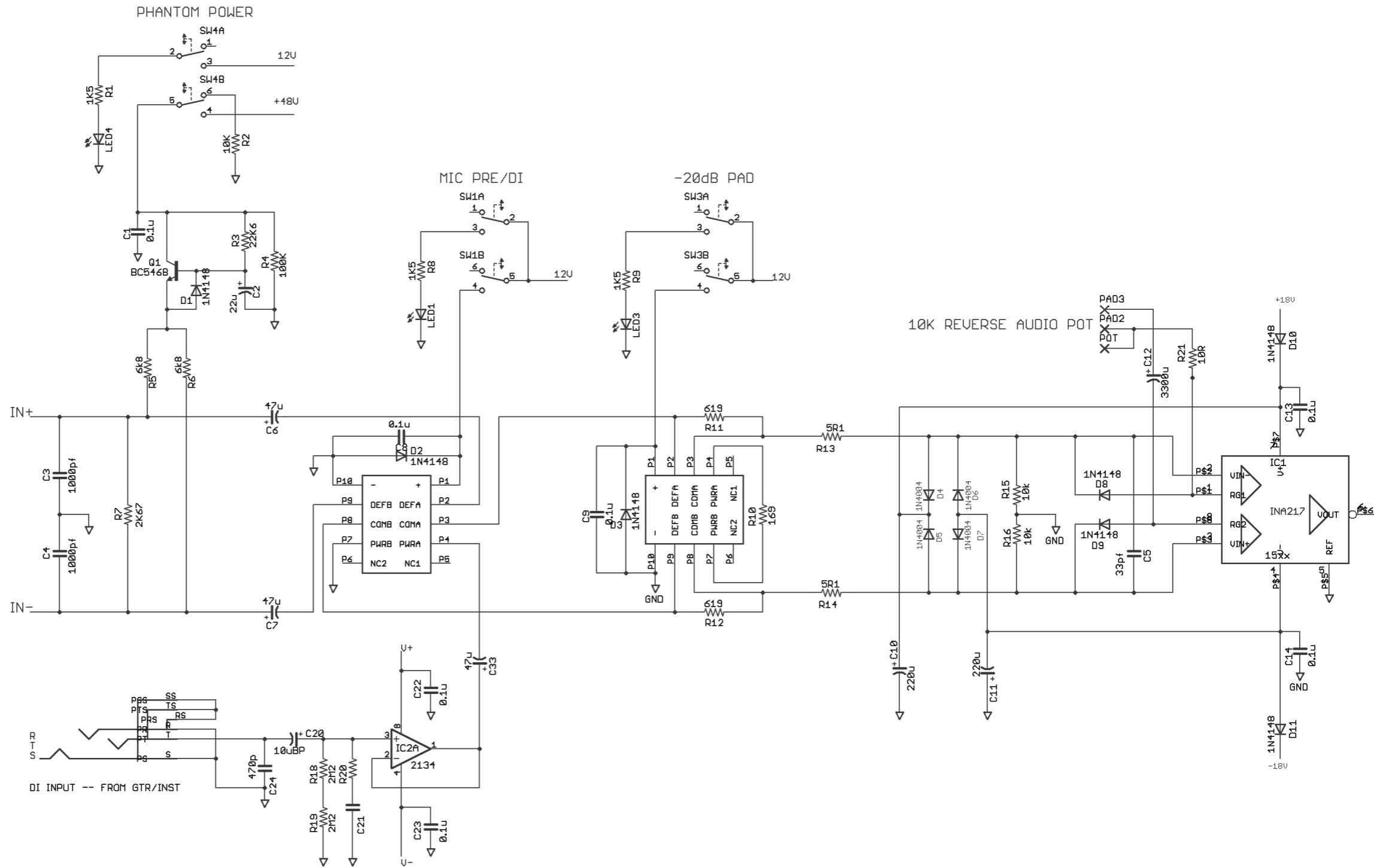

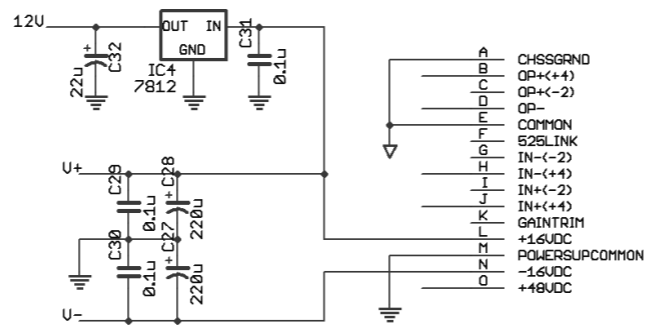

POLARITY REVERSE

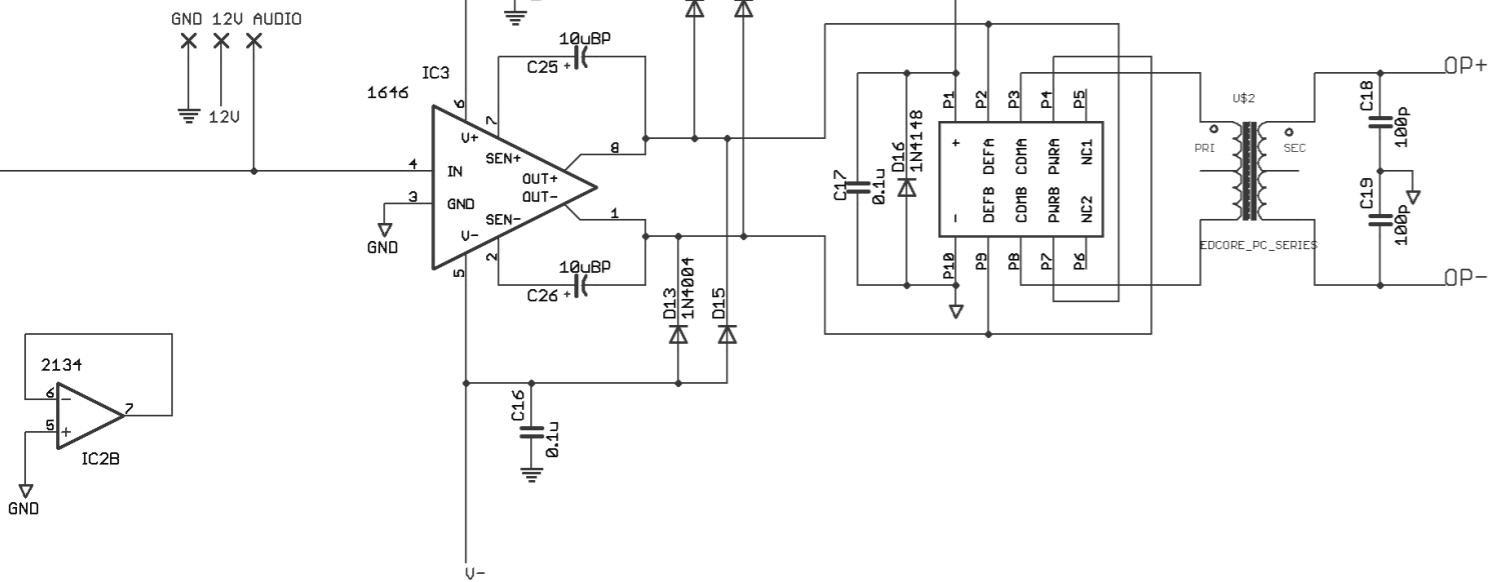
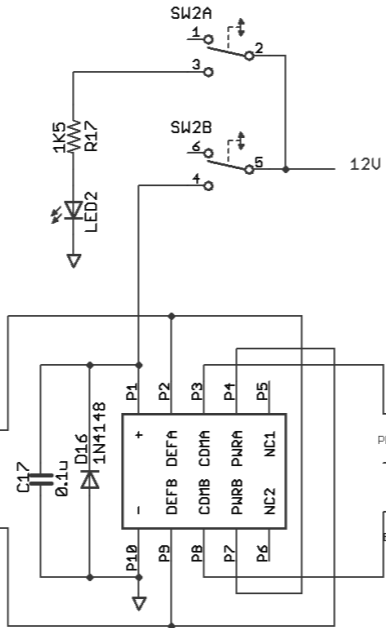



## 9. TROUBLESHOOTING INFORMATION

Hey, we're all human and make mistakes. Hopefully the tips below will help you troubleshoot your SK-1DI Mic Preamp build.

**I have no output signal. All LED lights work, and I can hear the relays clicking. The VU Meter also display signals but I don't hear anything on the output.**

If you are *\*NOT\** using an output transformer, make sure to attach jumper wires across the Output Transformer terminals? See Step 3.16.

**When I turn the gain knob clockwise, the sound decreases instead of increasing. At minimum gain setting, I have a very loud output signal. It's backwards!**

Please review Step 3.15 and look closely at how the wires are connected to the potentiometer. You need to swap the location of your 2 wires if your gain is backwards.

**I hear a popping sound when I switch from DI Instrument to Mic Input. I'm using a Condenser microphone with 48Volt phantom power switched ON.**

Turn OFF 48V Phantom Power switch and wait a few seconds before switching between DI Instrument and Mic Input or vice versa. Otherwise, you may get a popping sound if you switch between the (2) inputs, AND have 48V Phantom Power turned ON.

# 10. RACK MOUNTING THE SK-1DI MIC PREAMP MODULE

You may also mount the SK-1DI inside a custom 1u 19" rack case. Just supply the SK-1DI module with the necessary +/- voltages, and connect to XLR male and female jacks. Use the wiring guide below. You can use a 15-pin EDAC connector, or solder the connection wires directly to the holes provided on rear of the board.

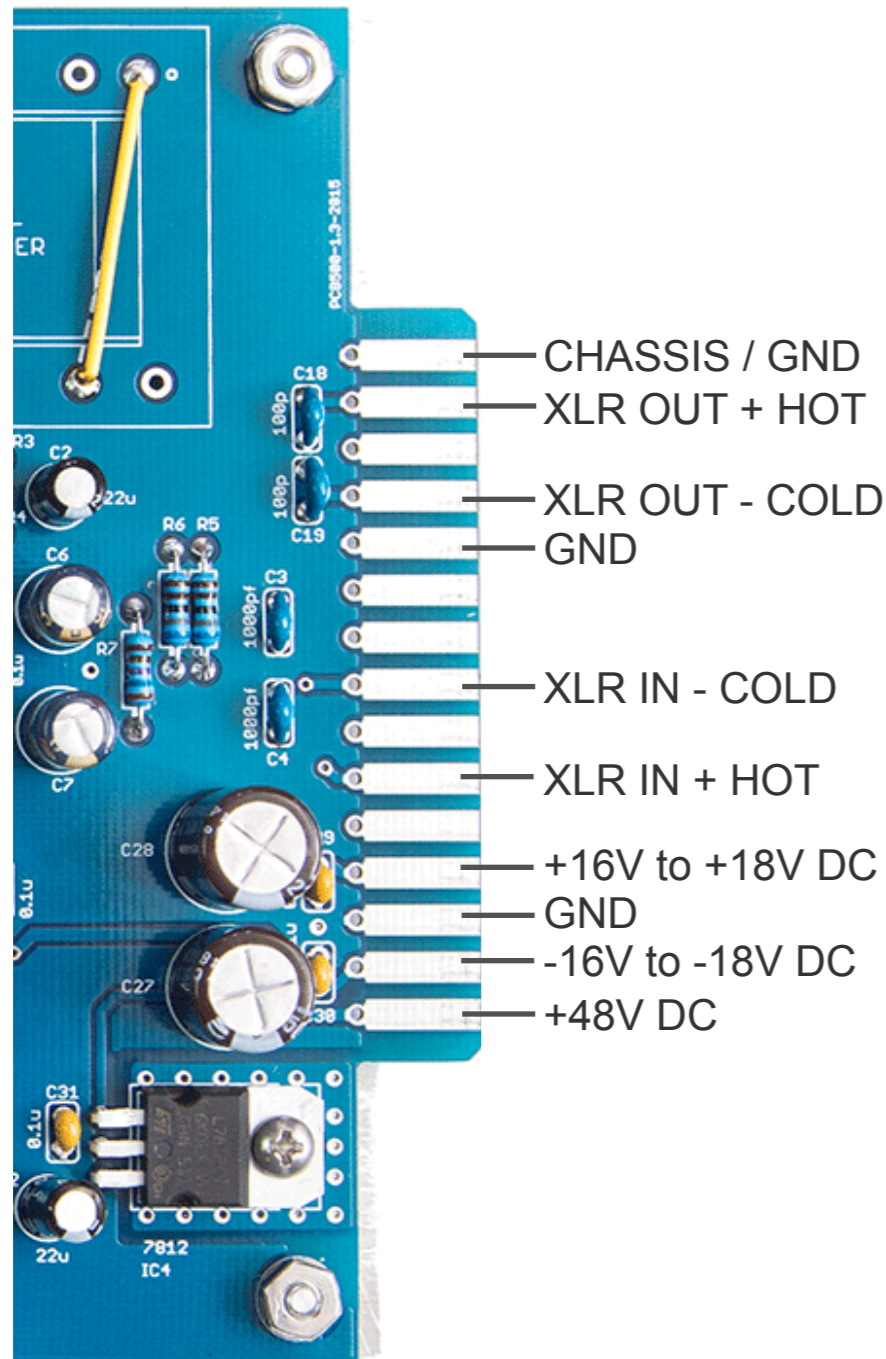

For rack mounting, we recommend a FiveFish PSU-2448 Power Supply Kit and Power Transformer to supply regulated +/- voltage and +48V phantom power to your SK-1DI module.

