

# PSU-4448mk2 Power Supply Kit

## Adjustable Twin Regulated Power Supply

*Simplicity Counts, Detail Matters.*

No part of this document may be reproduced, either mechanically or electronically, posted online on the Internet, in whole or in part, without the expressed, written permission of FiveFish Studios. This document is solely provided to the kit builder of the PSU-4448mk2 Power Supply Kit.

Copyright © 2008 FiveFish Studios  
[www.fivefishstudios.com](http://www.fivefishstudios.com)

Last Update: 08/14/08

## PSU-4448mk2 KIT

### Twin Regulated Power Supply

#### Assembly Guide Rev 1.0

This is a twin regulated power supply designed to supply the necessary voltages for racking a Yamaha PM1000 preamp module. The (2) rail voltages can be adjusted to +44V and +48V for use with the above preamp module.

It is a small form factor PSU, measuring only 3.25" (W) x 2.1" (H). The PCB is professionally manufactured, with double-sided copper, plated-through holes, and top silkscreen component labels.

**Specs: Regulated Voltages Output Range** (using PWR-TRAFO kit transformer)

Output 1: 22 Volts to 50+ Volts

Output 2: 22 Volts to 50+ Volts



A power transformer is required. **DO NOT CONNECT THE 110/220 AC LINES DIRECTLY TO THE PCB.**

AC Power can be supplied by either a 18-0-18, 20-0-20, or 22-0-22 VAC power transformer. For this discussion, I'm assuming you're using the 1U PWR-TRAFO kit that I'm selling (18+18)

If you are using a different brand/model of transformer, please consult the manufacturer for their own documentation.

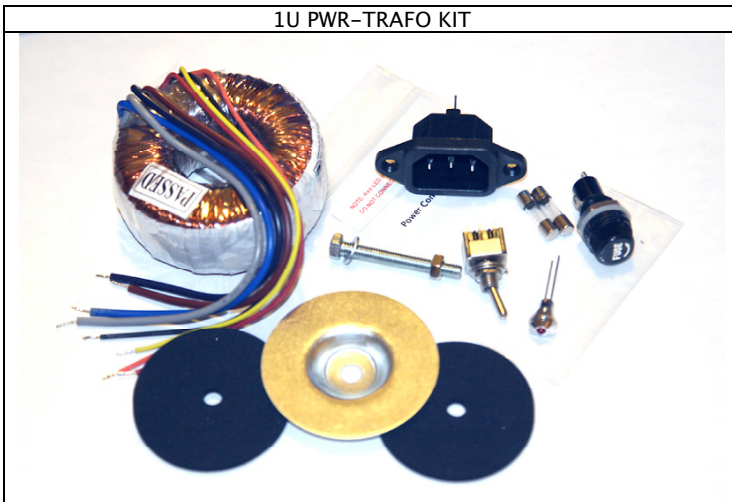

**USING THE 1U PWR-TRAFO KIT TRANSFORMER  
(photo shown above)**

**110 VOLT OPERATION**

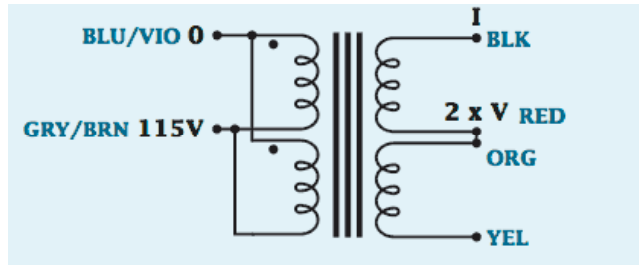

For 110V operation, we need to connect the primaries in parallel.

Connect the BLUE and VIOLET wires together.

Connect the GRAY and BROWN wires together.

Connect both across the 110V line.

**220 VOLT OPERATION**

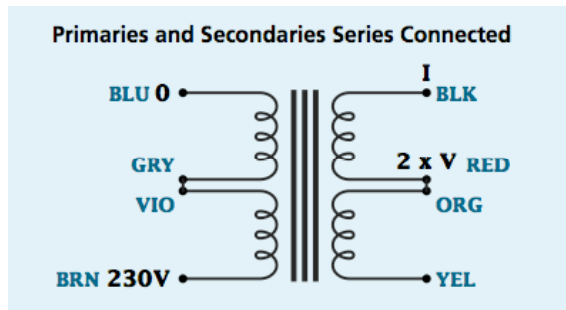

For 220V operation, we need to connect the 2 primaries in series.

Connect the GRAY and VIOLET wires together.

220V is applied across the BLUE and BROWN wires.

### For Both 110V or 220V OPERATION

On the secondary side, we need to connect the RED and ORANGE together, and insulate it with electrical tape.  
**DO NOT CONNECT THE RED AND ORANGE WIRES TO THE PCB.**

Connect the BLACK wire to AC1 on PSU PCB.

Connect the YELLOW wire to AC2 on PSU PCB.

### Basic Tools Required

A few basic tools are required to build this kit.

1. Soldering iron – adjustable temperature recommended, but not necessary. Your soldering iron must have a sharp conical tip. I do not recommend a “flat-head, screwdriver-type” soldering iron. **DO NOT USE A SOLDERING GUN.** They are usually rated at 100Watts and are overkill for this project.



2. Mini Pliers Cutter – to cut component leads, wires, strip insulation off wires (if you don't have a wire-stripper tool).
3. Mini Long Nose Pliers – to bend component leads, use as a heatsink, hold components, tighten bolts.



4. Manual Solder sucker pump – sucks up solder when you made a mistake soldering components on the PCB. Primitive operation, but it works... kind of.



5. Multitester – A simple meter/tester to measure resistance, and voltages. A digital read-out is a big help.



6. Soldering Lead – 60/40 lead or lead-free solder



7. Magnifying glass – to see what you're doing!



8. Clean and well-lighted work area – Lots of good lighting, clean work area. You want to be able to leave your work-in-progress without packing everything away.

Extra Tools (Nice to have, but not required)

1. Vacuum desoldering pump – if you make a mistake, you need to pull out the component from the PCB
2. Component lead bender – bend component leads like resistors uniformly and evenly
3. PanaVise – to hold PCB while you're working on it
4. Tweezers – to pick tiny things
5. Masking tape – to hold components on the PCB while working
6. Wire-stripper – for cutting wires and stripping its insulation

## PSU-4448MK2 Assembly Guide

Follow these instructions to assemble your PSU-1848 Power Supply. Bend the component leads like the photo shown below before inserting them to the PCB. For diodes, allot a small clearance before bending the leads.



Step 1. Solder all resistors and diodes to the PCB. (R1,R2,R3,R4,R5,R6,R7,R8,D1,D2,D3,D4)

When soldering D1 to D4, watch for the orientation of the diodes. The Diode has a small white band on one end. Follow the marked diagram on the PCB with regards to where the white band should be located. (TIP: All white bands are oriented on top)

Step 2. Solder all ceramic capacitors to the PCB. These are the small yellow components. (C5,C6,C11,C12)

Step 3. Solder the bridge rectifier RECT1,. This is the small circular components that have a "chopped-off" side. Note the proper orientation. Follow the guide printed on the PCB. The "flat" side is pointed towards the left direction.

Step 4. Solder the supplied LED1 and LED2. The long leg should be inserted on the RIGHT position.

Step 5. Solder all small electrolytic capacitors. (C3, C4, C9, C10)

Step 6. Solder the trimmer resistors, R3, R7. These are the blue rectangular components with an adjustment screw on top.

Step 7. Solder capacitors, C1, C2, C7, C8. These are snap-in type capacitors. You may need to do a slight twisting motion when inserting these capacitors into the holes. They should "snap" and be completely flat on the board.

Step 10. Solder voltage regulators IC1, IC2. For aesthetic reasons, keep all their height at the same level. The flat side (i.e. metal side) of the regulators should be facing out towards the top edge of the PCB.

Step 11. Install TO-220 heatsinks to your regulators. Use small nut and bolts to fasten the heatsinks to the regulators. You don't need to install insulators. Just make sure the 2 heatsinks do not touch each other, or the metal part of your case.

Step 12. Wire the PCB to your power transformers. Follow the wiring diagram shown above for proper 110V or 220V operation.

## PSU-4448MK2 Voltage Adjustment Guide

### +44V Adjustment



**Actually, both outputs can be adjusted to whatever voltage you need... 45V, 46V, etc.**

1. Using a voltmeter, measure the voltage across the (+44V) and GND pad. We want a voltage reading of +44Volts. You probably won't exactly get 44Volts, so using a small screwdriver, adjust the left trimmer screw to get a reading of 44Volts.
2. Using a voltmeter, measure the voltage across the (+48V) and GND pad. We want a voltage reading of +48Volts. You probably won't exactly get 48Volts, so using a small screwdriver, adjust the right trimmer to get a reading of 48Volts.
3. DONE! FINISH

## PSU-4448mk2 Parts List

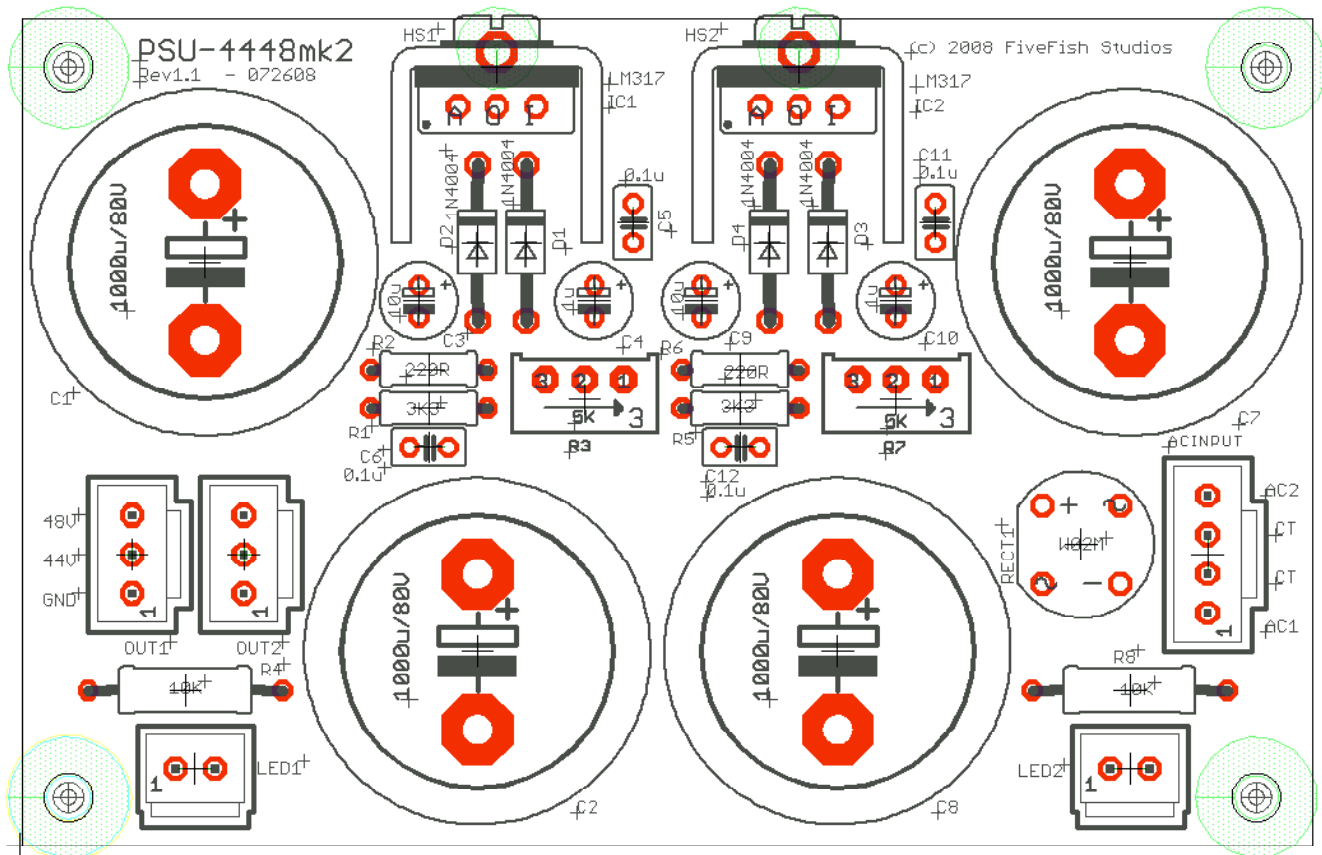
**PSU-4448 mk2**

Part	Value
IC1, IC2	LM317T
D1,D2,D3,D4	1N4004
RECT1	W02G rectifier
LED1,LED2	LITE-ON LED
R1,R5	3K3 or 3K57
R2,R6	220R
R3,R7	5K TRIM
R4,R8	10K or higher (higher value = dimmer light)
C1,C2,C7,C8	1000uf 80V
C3,C9	10u 63V
C4,C10	1u 100V
C5,C6,C11,C12	0.1u 100V
HS1,HS2	HS-140 for TO-220
PCB	PSU-4448mk2 Custom PCB



